

5	
4	
3	
2	
1	
Table of Contents	
Page	
3	Block Diagram
4	TOP
5	CPU Interfaces
6	DDR2 & Flash
7	PERIPHERALS
8	CPU Power
9	ELEVATOR CONNECTORS
10	OSBDM
11	Power from OSBDM

Revisions			
Rev	Description	Date	Designer
A	Original Release	8/1/2009	Swann Zhou
B	Modify according to ECR	11/18/2009	Swann Zhou
B1	Revise	5/18/2010	Jun Qiao
B2	Revise	5/20/2010	Jun Qiao
B3	Revise	5/26/2010	Jun Qiao
B4	Revise	6/8/2010	Jun Qiao
B5	Revise	6/9/2010	Jun Qiao
B6	Revise	6/17/2010	Jun Qiao
C	Release	6/21/2010	Jun Qiao
C1	Revise	7/23/2010	Jun Qiao

		Microcontroller Solutions Group	
		6501 William Cannon Drive West Austin, TX 78735-8598	
This document contains information proprietary to Freescale Semiconductor and shall not be used for engineering design, procurement or manufacture in whole or in part without the express written permission of Freescale Semiconductor.			
		ICAP Classification: FCP: FIUC: X PUB:	
Designer: Jim Williams	Drawing Title: TWR-MCF5441X		
Drawn by: Jun Qiao	Page Title: TITLE PAGE		
Approved:	Size C	Document Number SCH-26131 PDF: SPF-26131	Rev C1
Date: Friday, July 23, 2010		Sheet 1 of 11	



otherwise Specified:

All polarized capacitors are DC

All polarized capacitors are aluminum electrolytic

2. Interrupted lines coded with the same letter or letter combinations are electrically connected.

3. Device type number is for reference only. The number varies with the manufacturer.

4. Special signal usage:

_B Denotes - Active-Low Signal

<> or [] Denotes - Vectored Signals

5. Interpret diagram in accordance with American National Standards Institute specifications, current revision, with the exception of logic block symbology.

ICAP Classification: FCP: FIUQ: X PUBI:		
Drawing Title: TWR-MCF5441X		
Page Title: NOTES		
Size C	Document Number SCH-26131 PDF: SPF-26131	Rev C
Date: Tuesday, June 22, 2010	Sheet 2 of 11	1

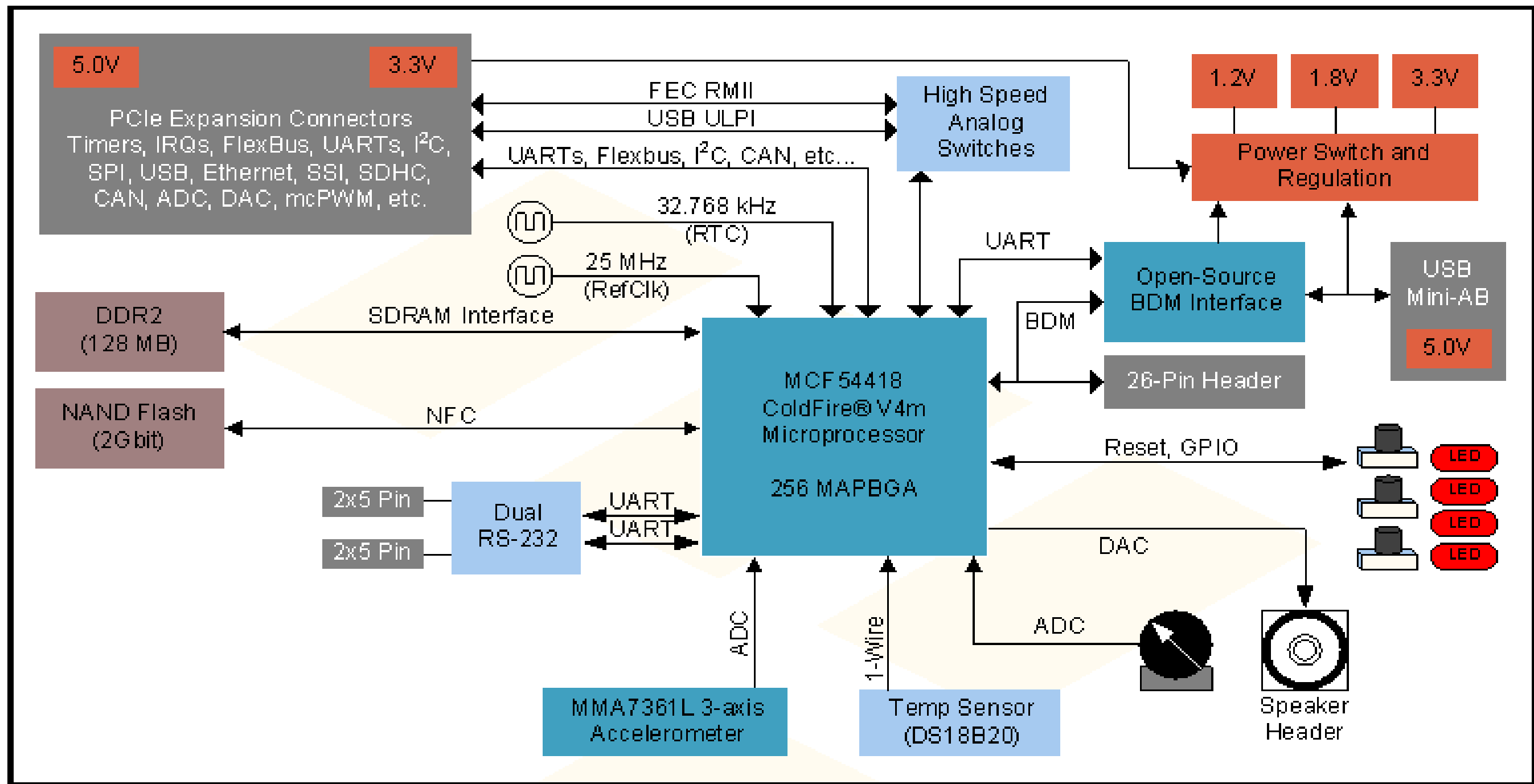

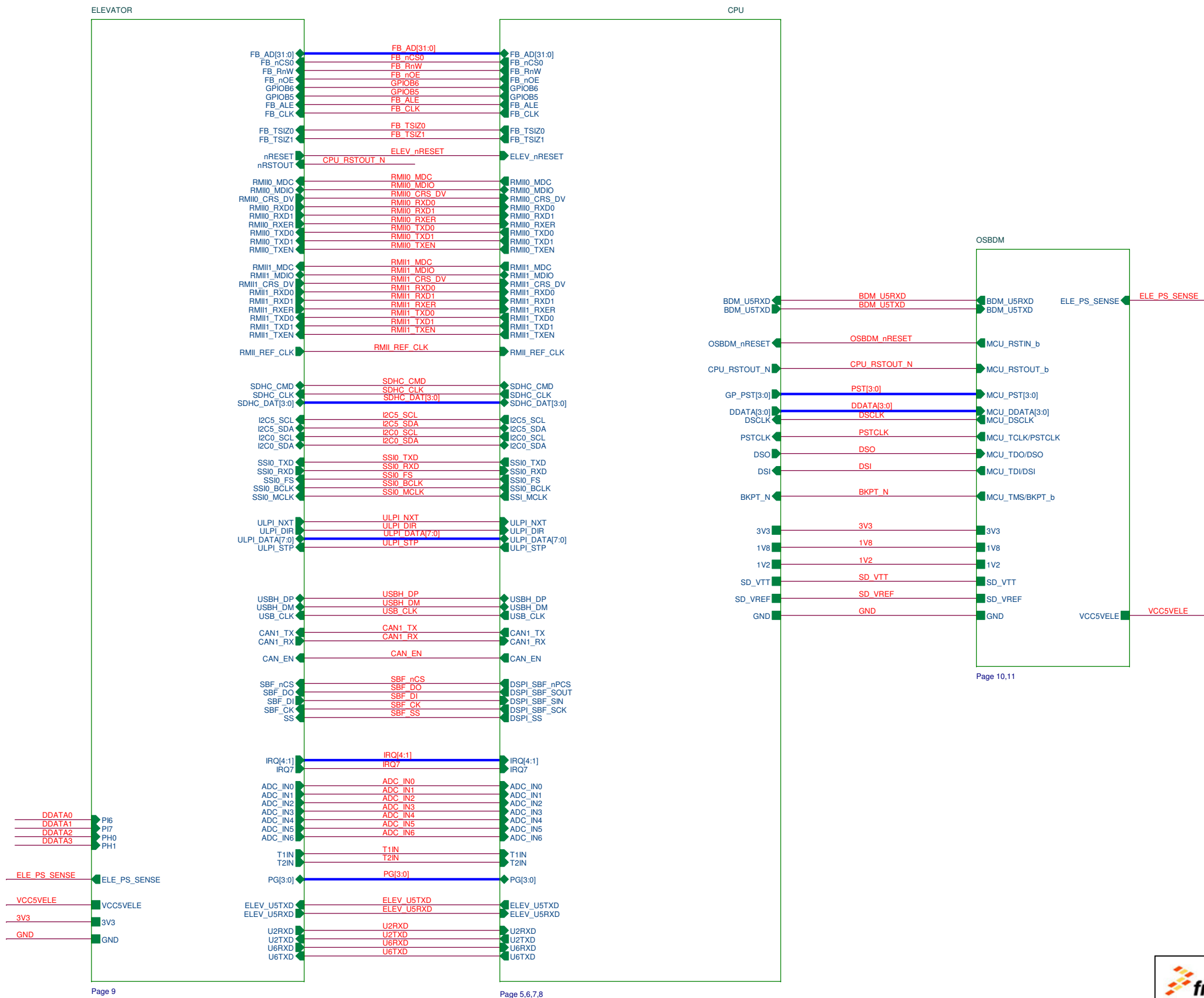

freescale
semiconductor

ICAP Classification: FCP: FIUQ: X PUBI:
Drawing Title:
TWR-MCF5441X

Page Title:
TOP

Size C	Document Number SCH-26131 PDF: SPF-26131	Rev C1
Date: Friday, July 23, 2010	Sheet 4 of 11	

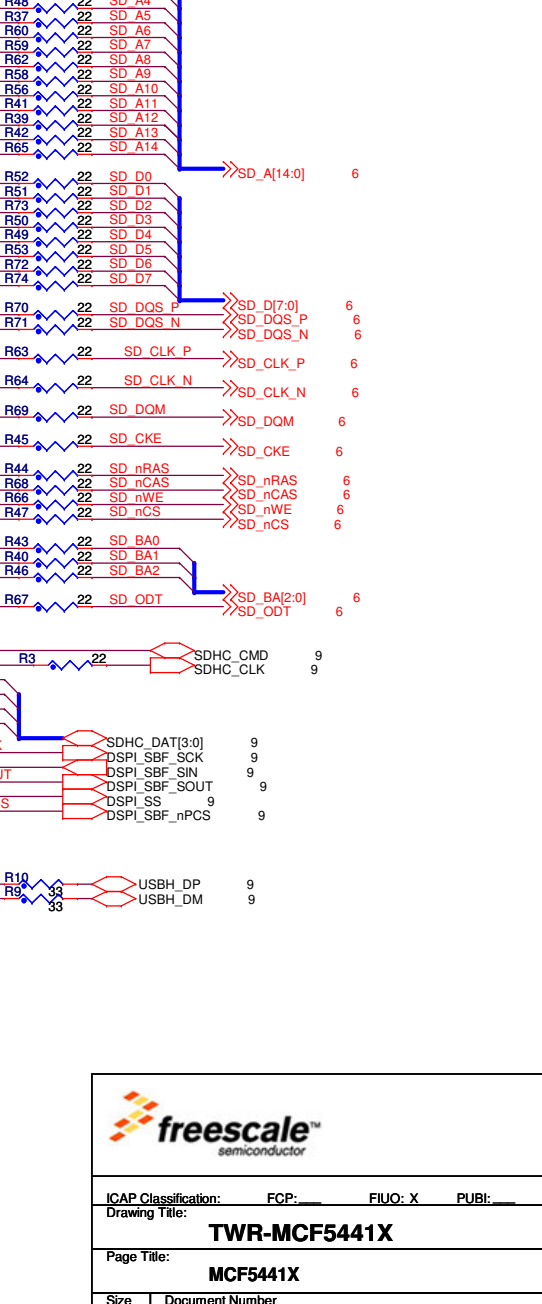
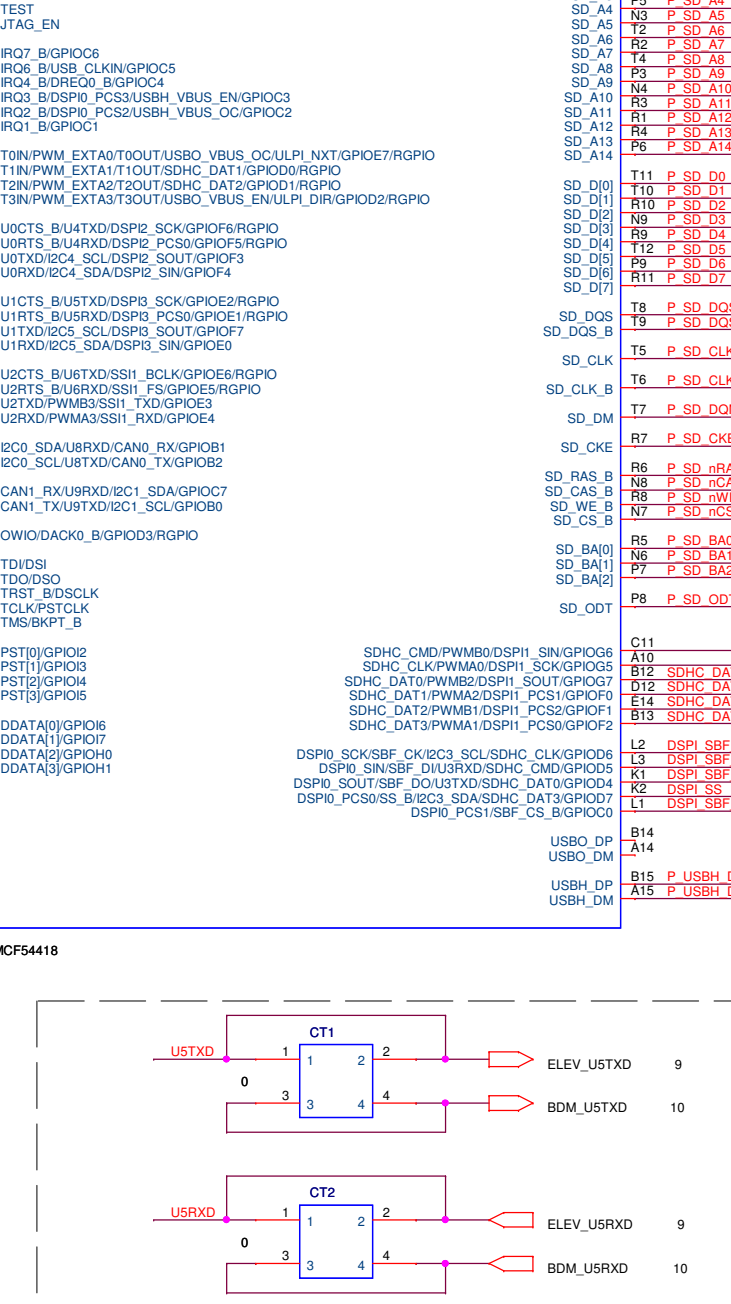
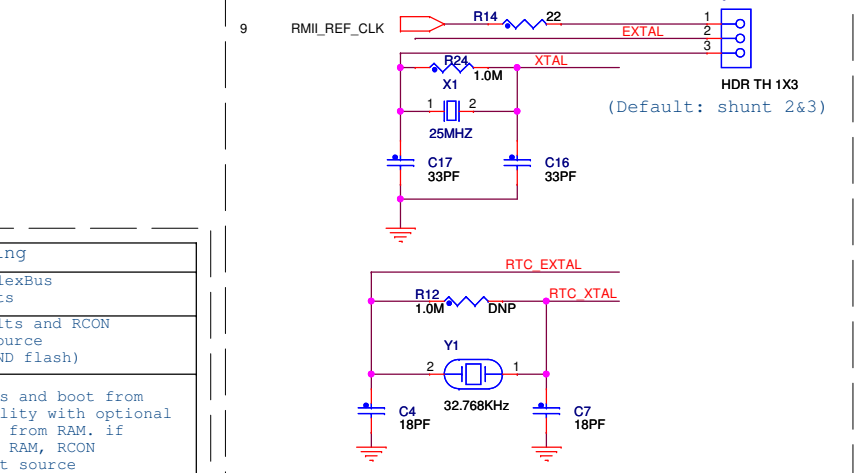
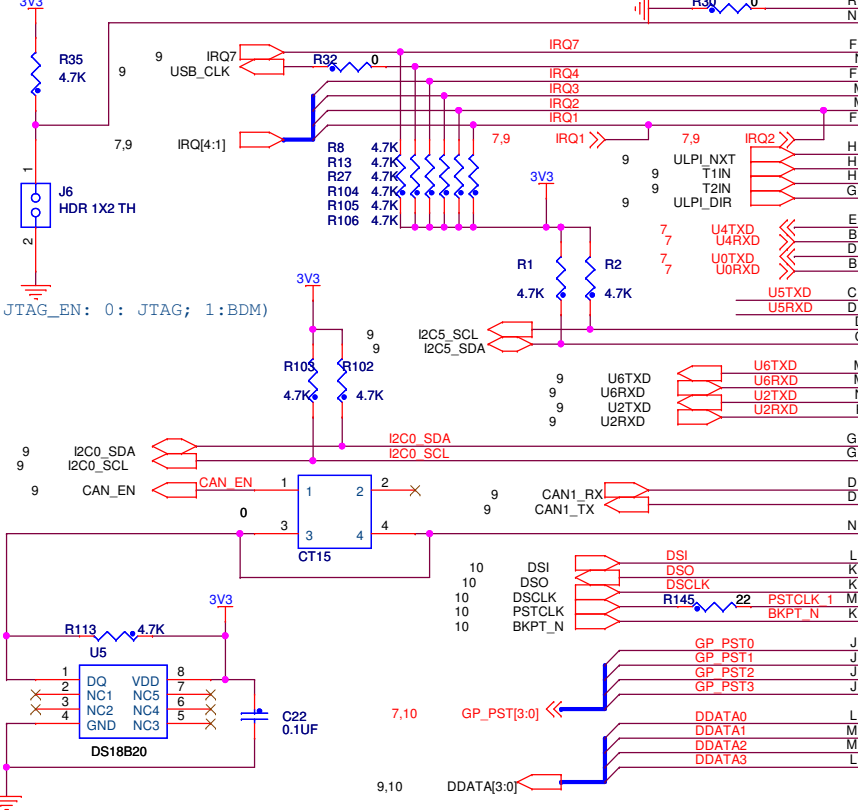
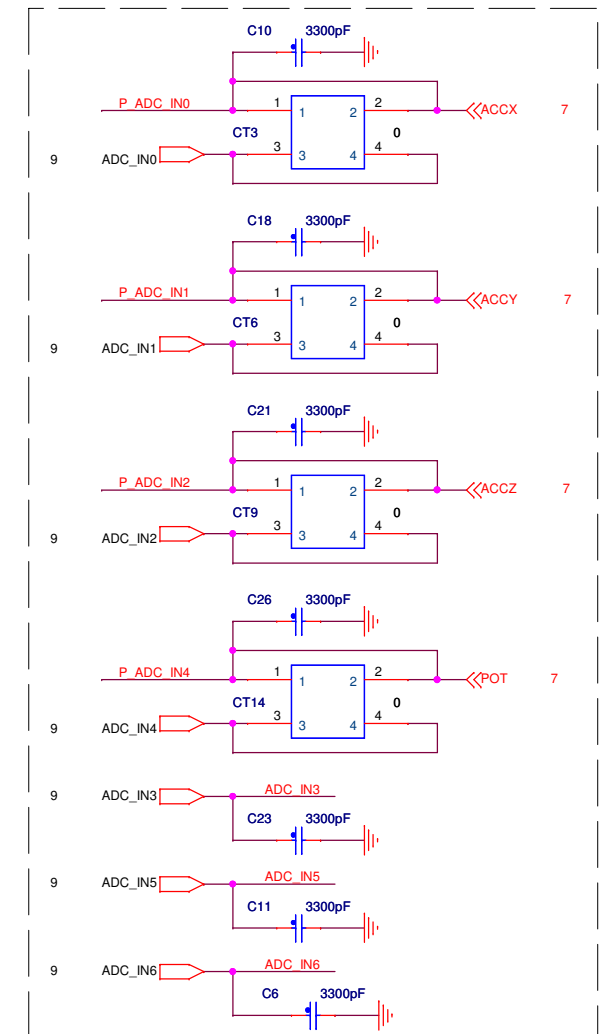
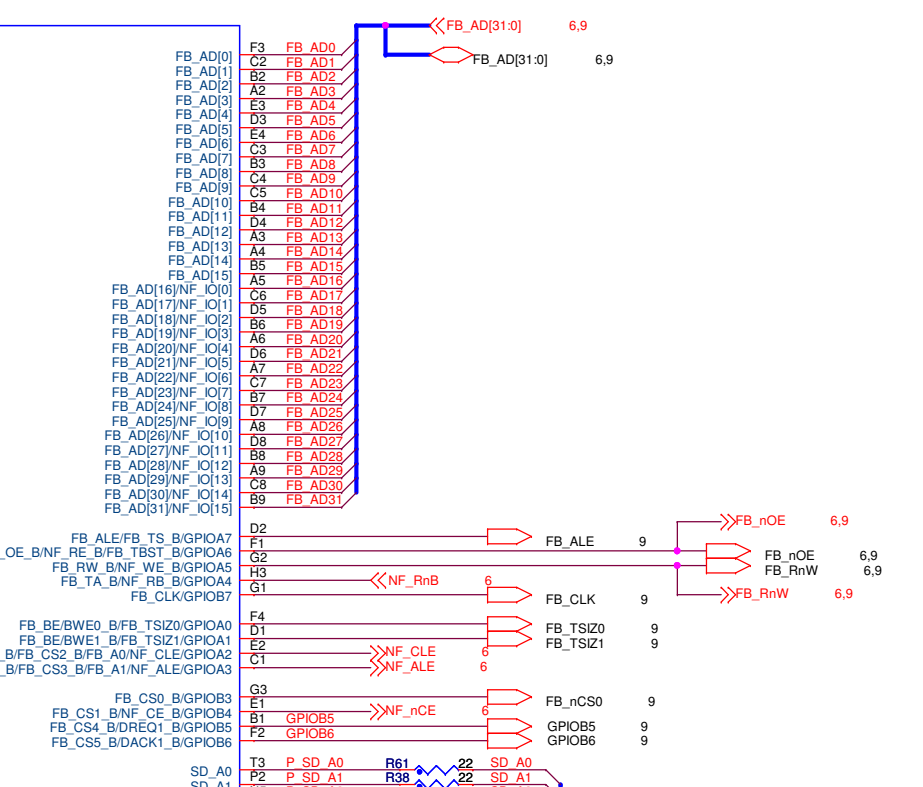
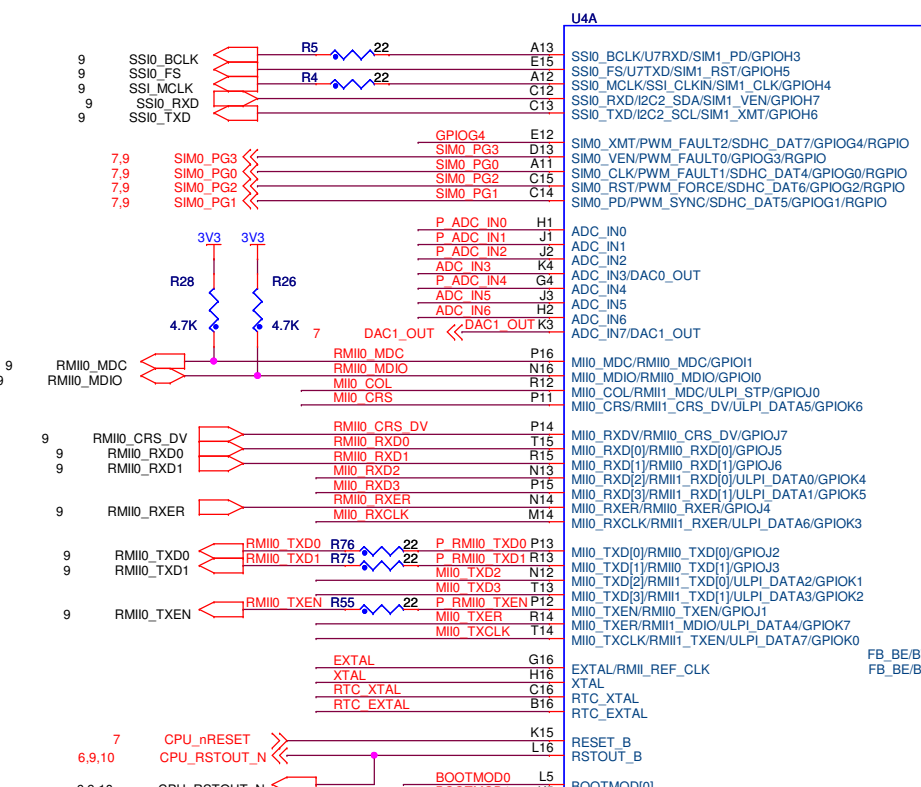
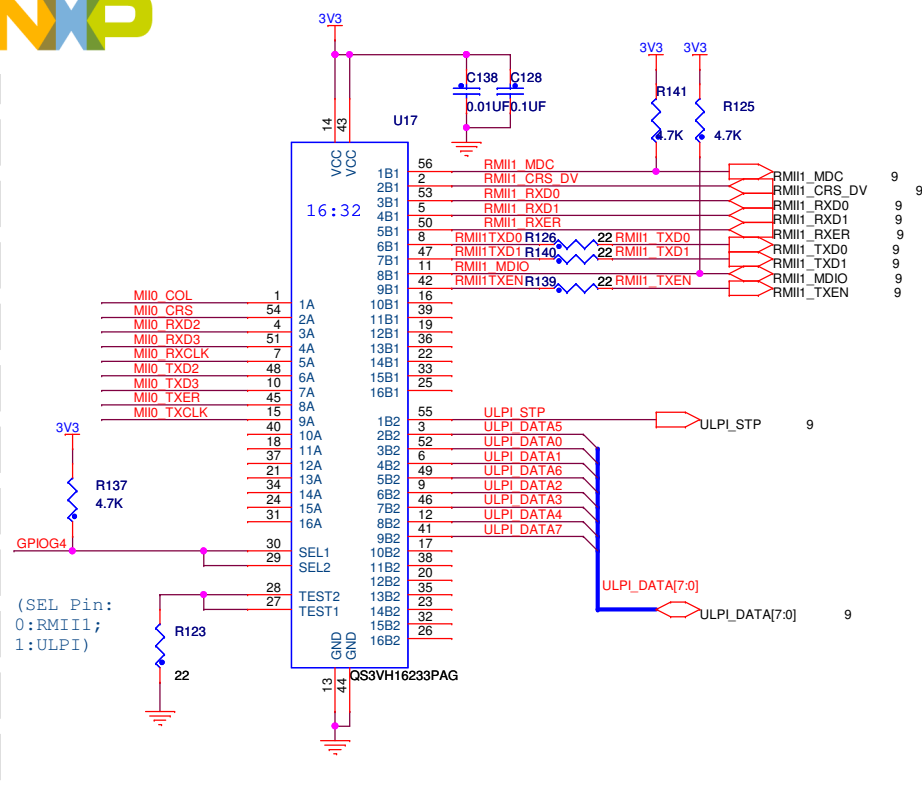

(BOOT MODE Setting)

(Default: shunt 3,4)

BOOTMOD[1:0]	Meaning
00	Boot from FlexBus with defaults
01	Override defaults and RCON decides boot source (FlexBus or NAND flash)
1x	Override defaults and boot from serial boot facility with optional load to and boot from RAM. if not booting from RAM, RCON decides the boot source (FlexBus or NAND flash)

ICAP Classification: FCP: FIUC: X PUBL:

Drawing Title: **TWR-MCF5441X**

Page Title: **MCF5441X**

Size C	Document Number SCH-26131 PDF:SPF-26131	Rev C1
--------	---	--------

Date: Friday, July 23, 2010 Sheet 5 of 11

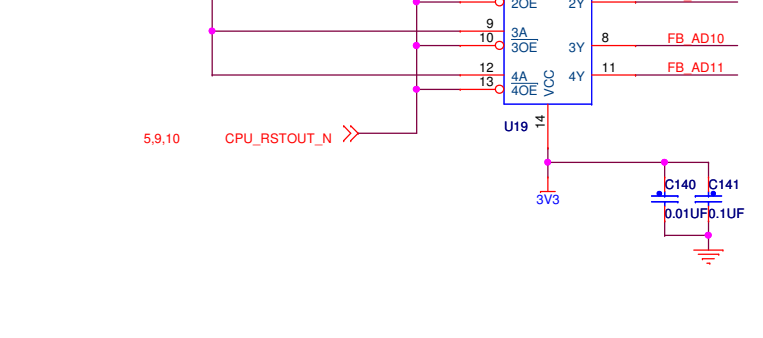
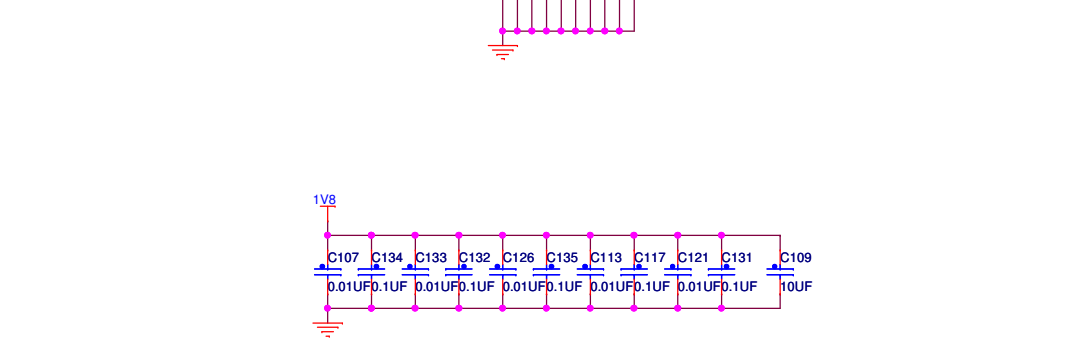
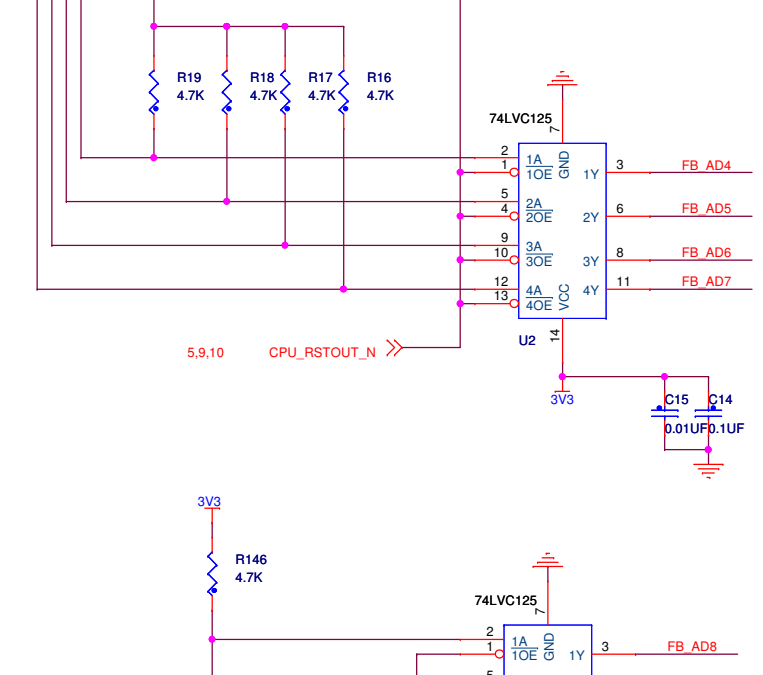
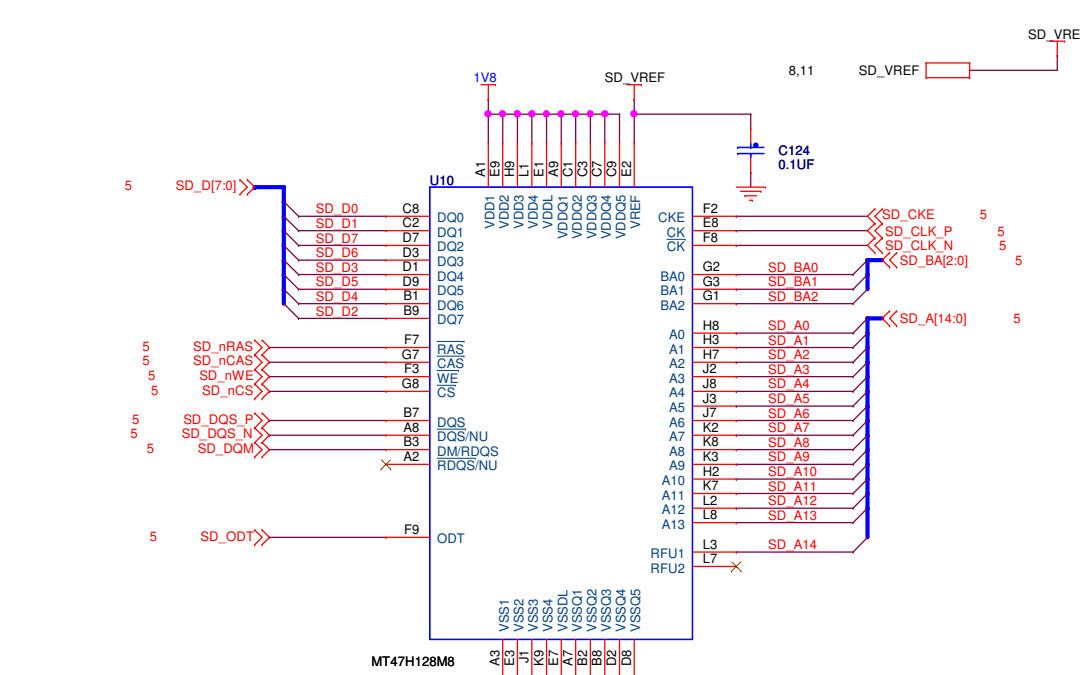
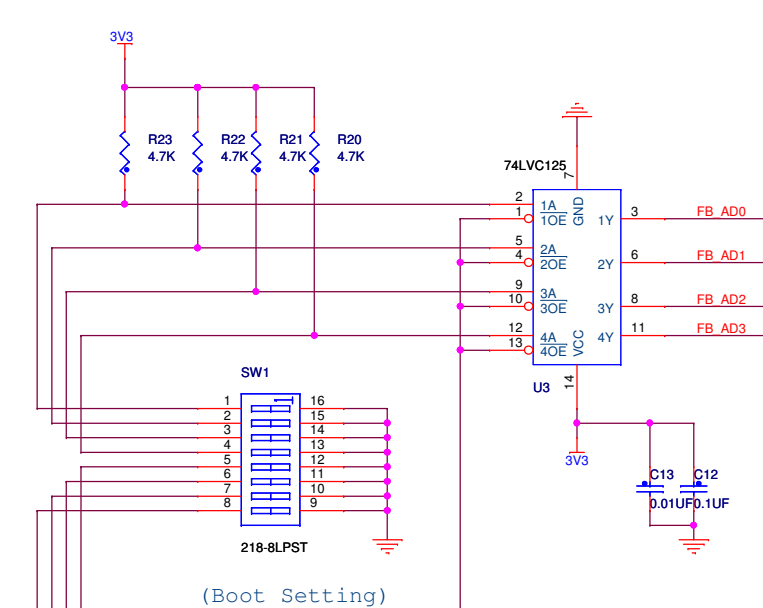
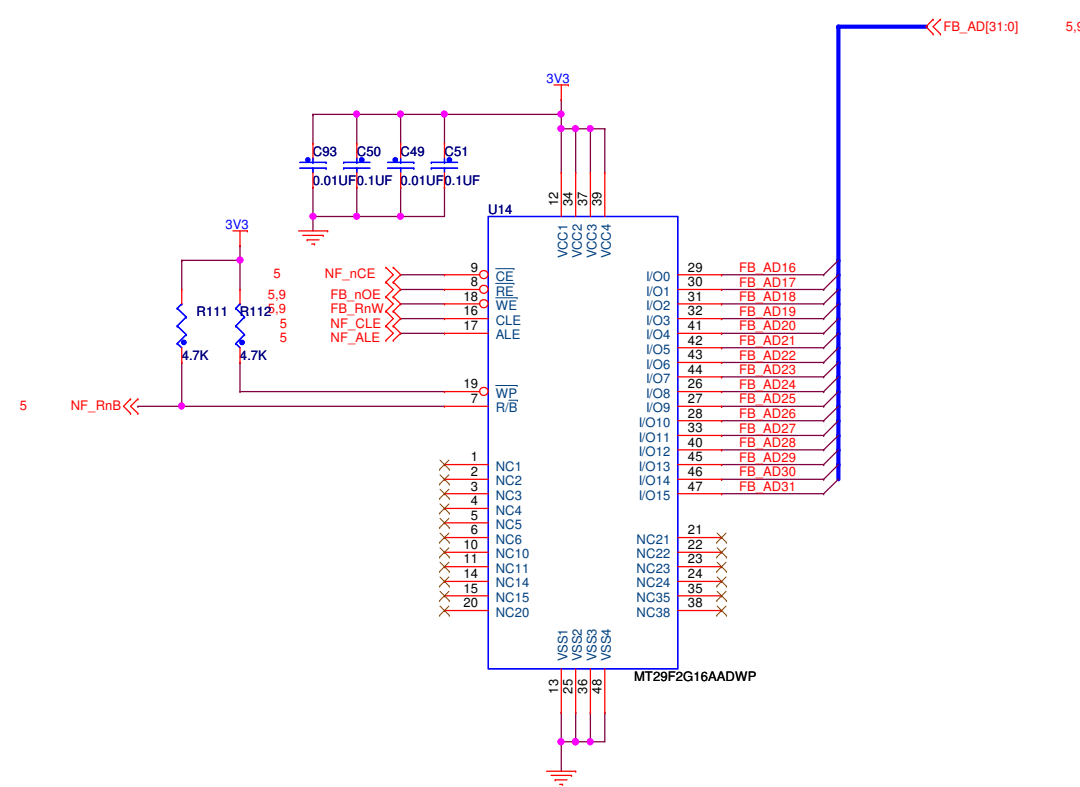

Parallel Configuration During Reset when BootMod[1:0]= 01

Override Pins in Reset	Function
FB_AD0	Boot memory
0	NAND flash
1	FlexBus
FB_AD1	PLL mode
0	Disabled
1	Enabled
FB_AD2	Oscillator mode
0	Crystal oscillator mode
1	Oscillator bypass mode
FB_AD3	FB_ALE select
0	FB_TS_B
1	FB_ALE
FB_AD[5:4]	BOOT Port Size
00	32-bit(32-bit muxed address)
01	8-bit(24-bit non-muxed address)
10	16-bit(16-bit non-muxed address)
11	16-bit(16-bit non-muxed address)
FB_AD[7:6]	PLL Multiplier
00	Fvco = 10 x Fref
01	Fvco = 15 x Fref
10	Fvco = 16 x Fref
11	Fvco = 20 x Fref

ICAP Classification: FCP: FIUO: X PUBI:
 Drawing Title: **TWR-MCF5441X**
 Page Title: **DDR2 & Flash**
 Size C Document Number SCH-26131 PDF: SPF-26131 Rev C
 Date: Friday, July 23, 2010 Sheet 6 of 11

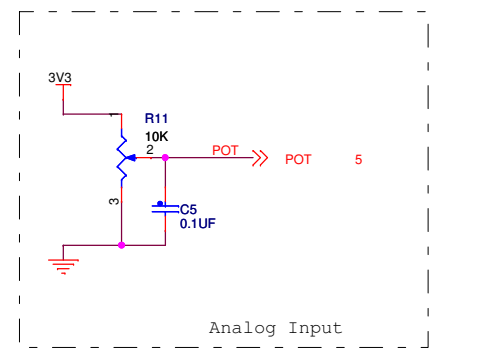
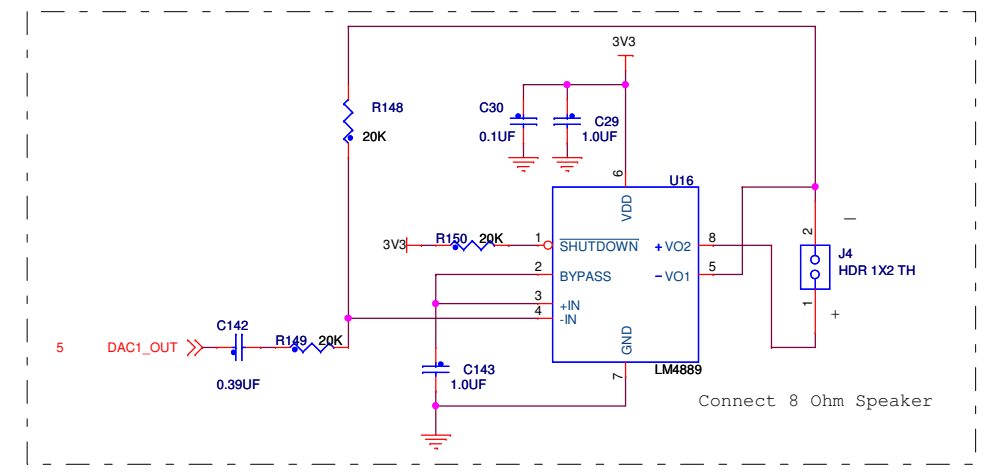
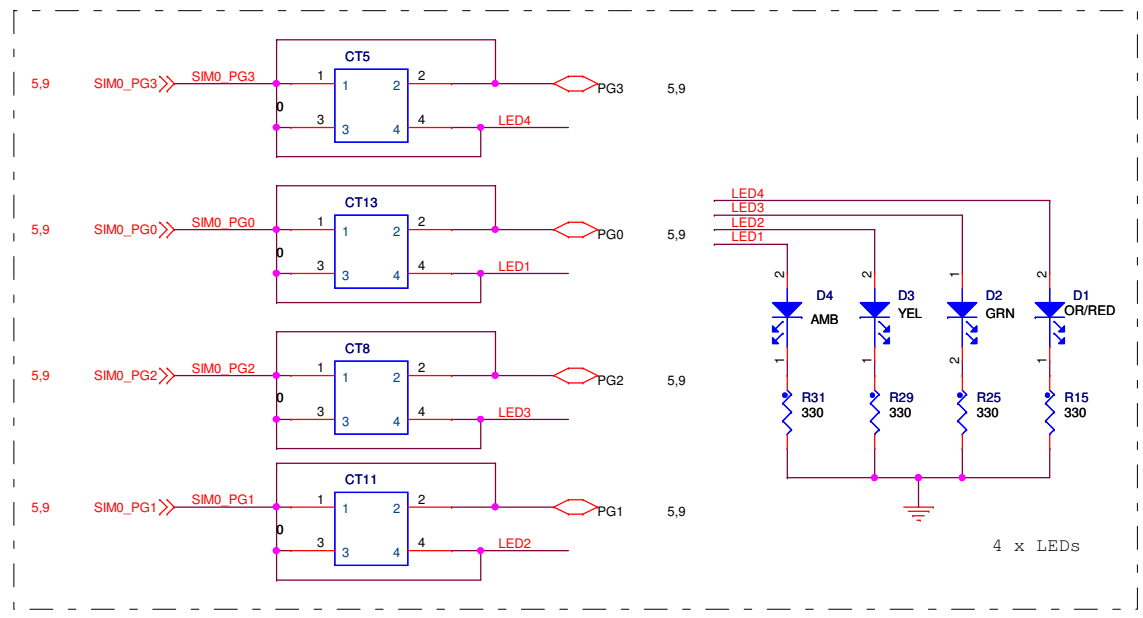
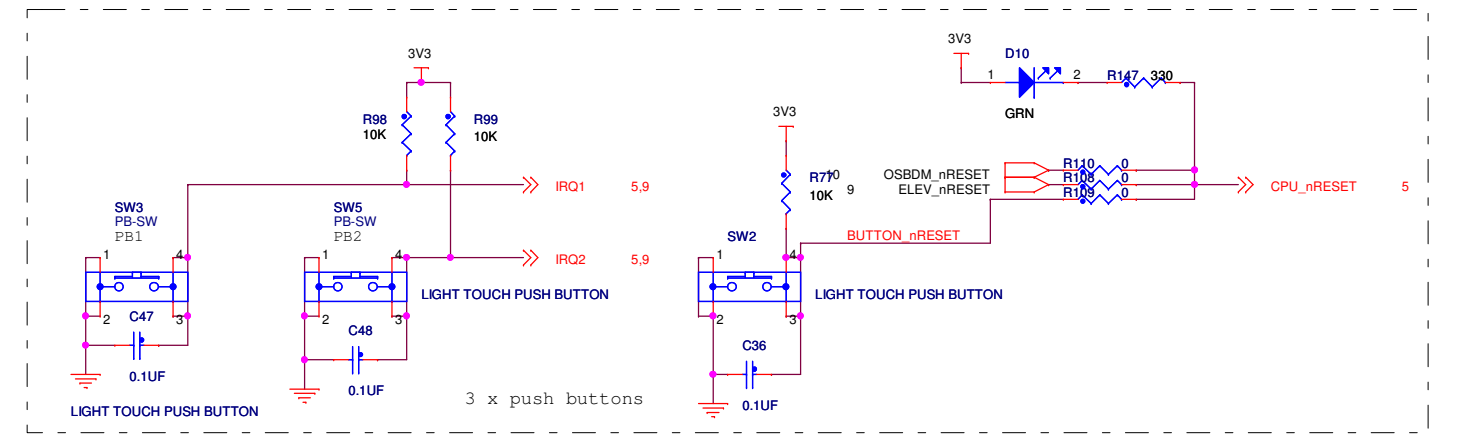
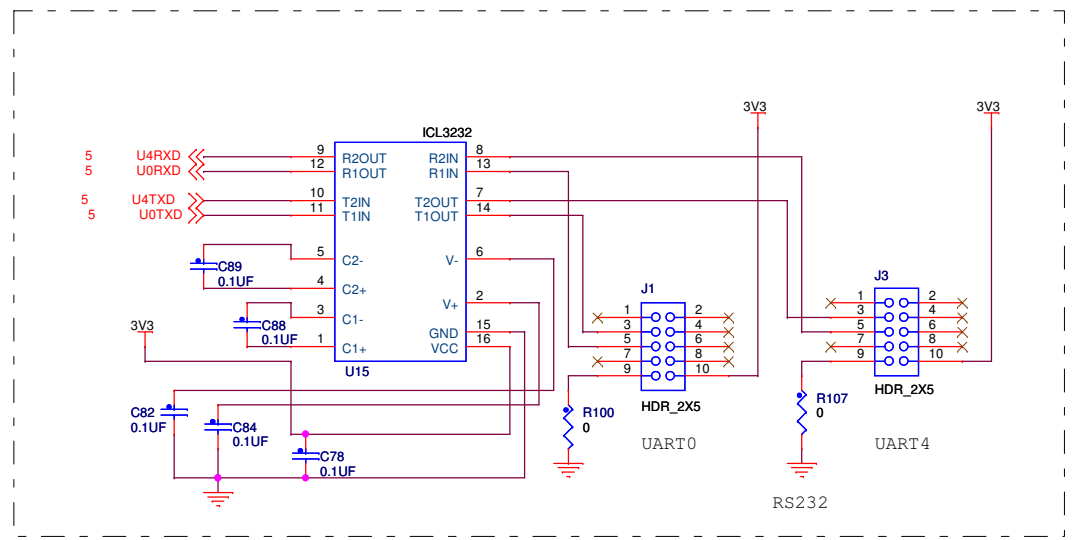
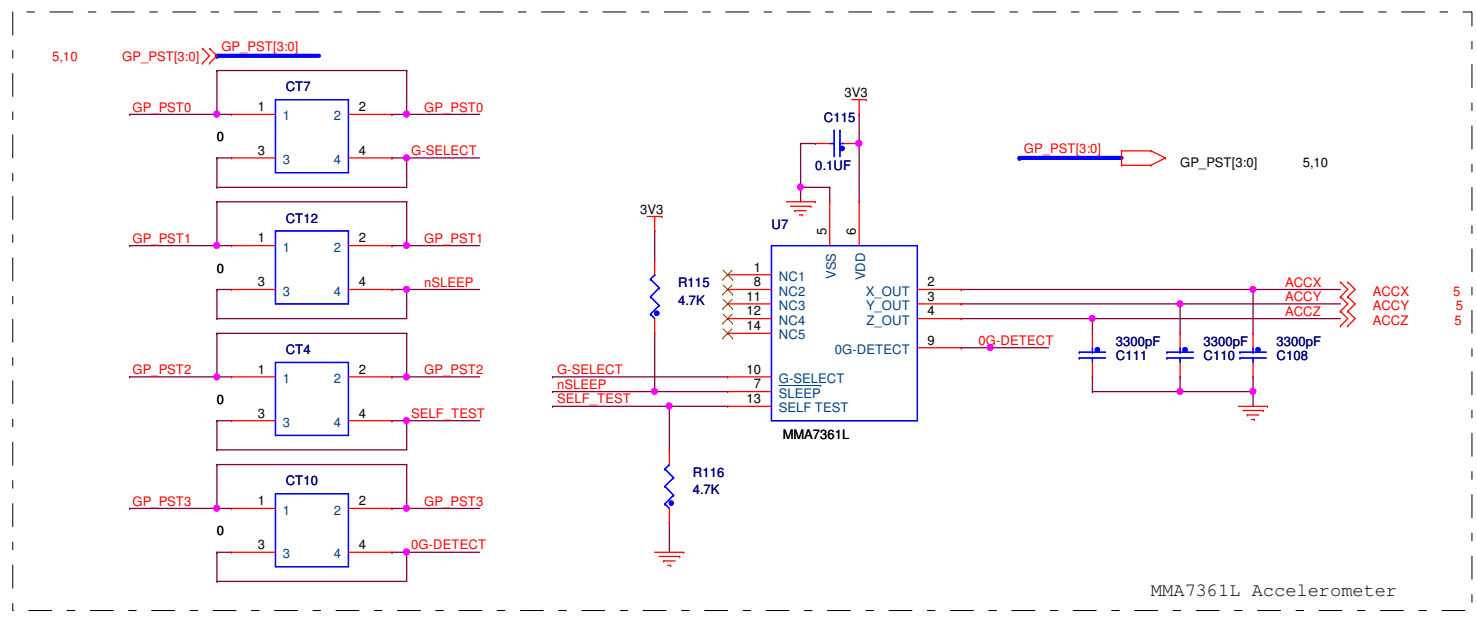

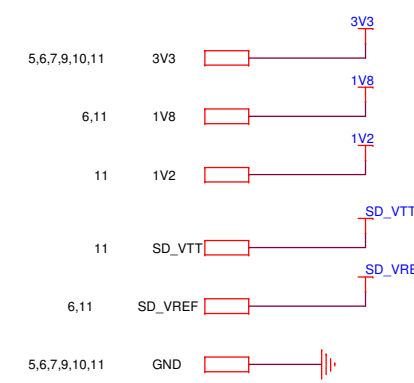
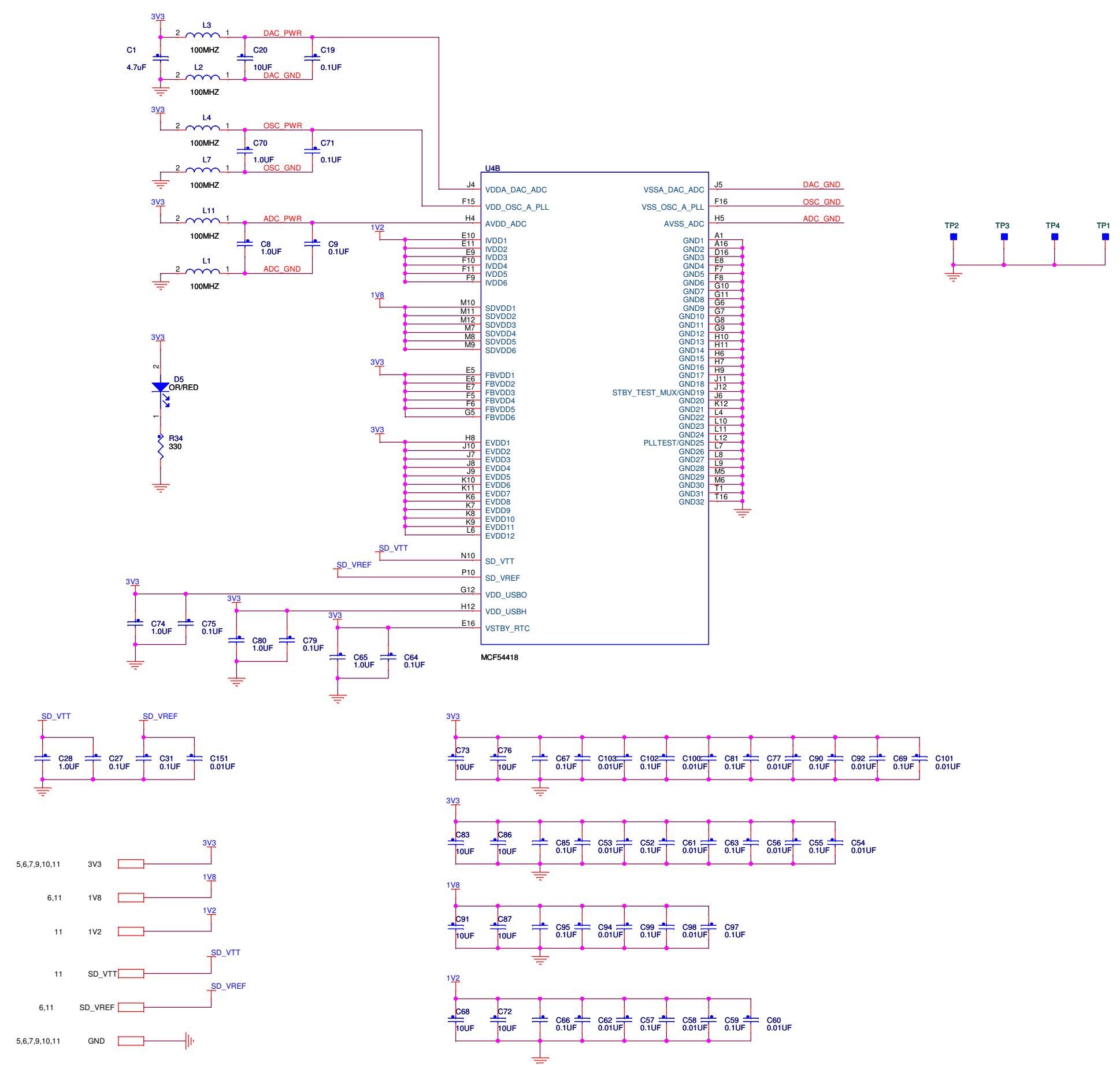

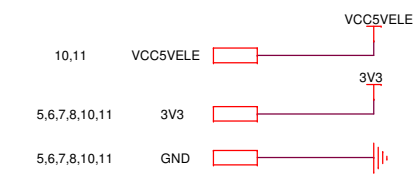
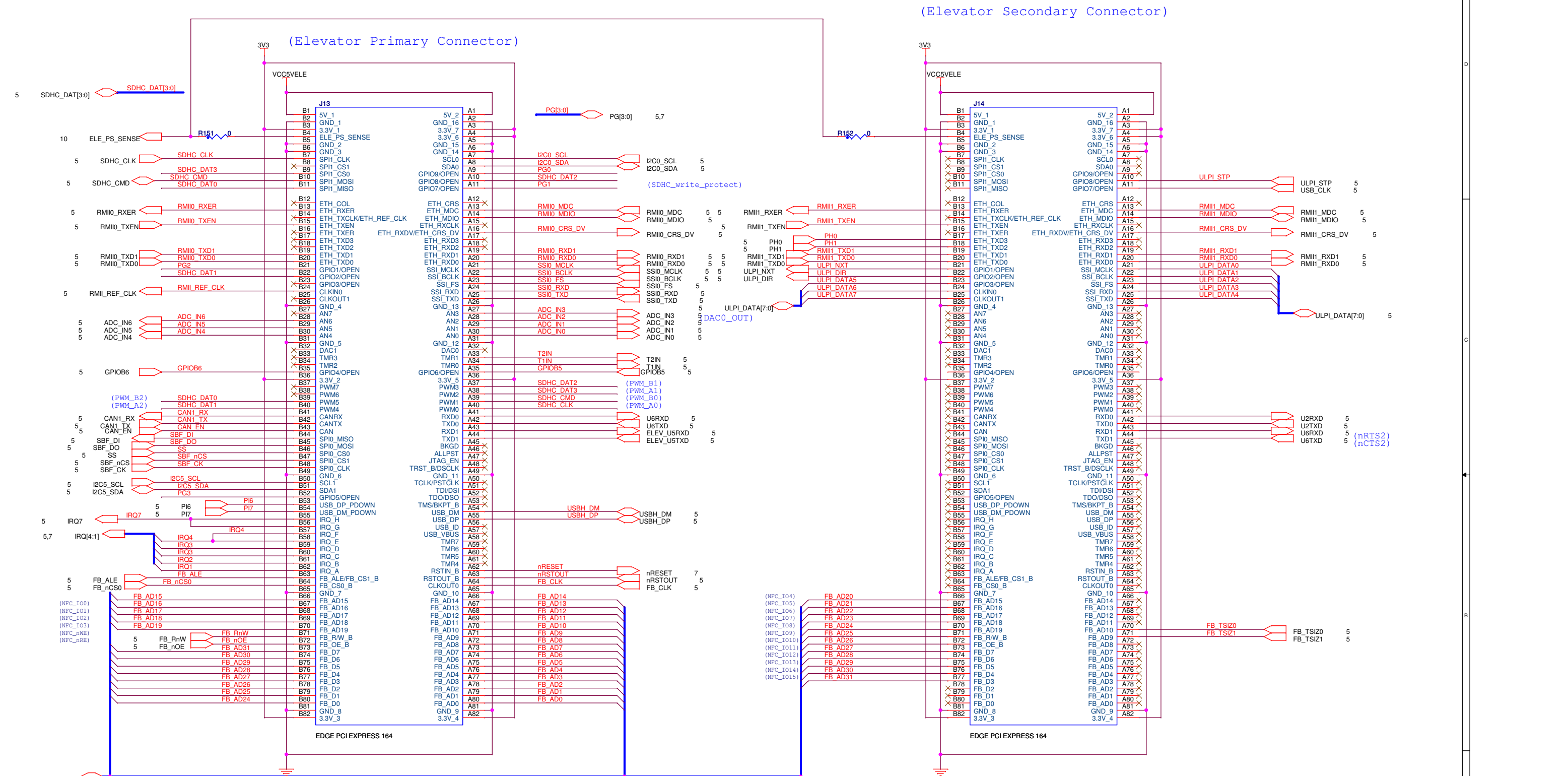

freescale
semiconductor

ICAP Classification: FCP: FIUC: X PUBL:

Drawing Title: **TWR-MCF5441X**

Page Title: **ELEVATOR CONNECTORS**

Size C	Document Number SCH-26131 PDF: SPF-26131	Rev C1
--------	--	--------

Date: Friday, July 23, 2010 Sheet 9 of 11

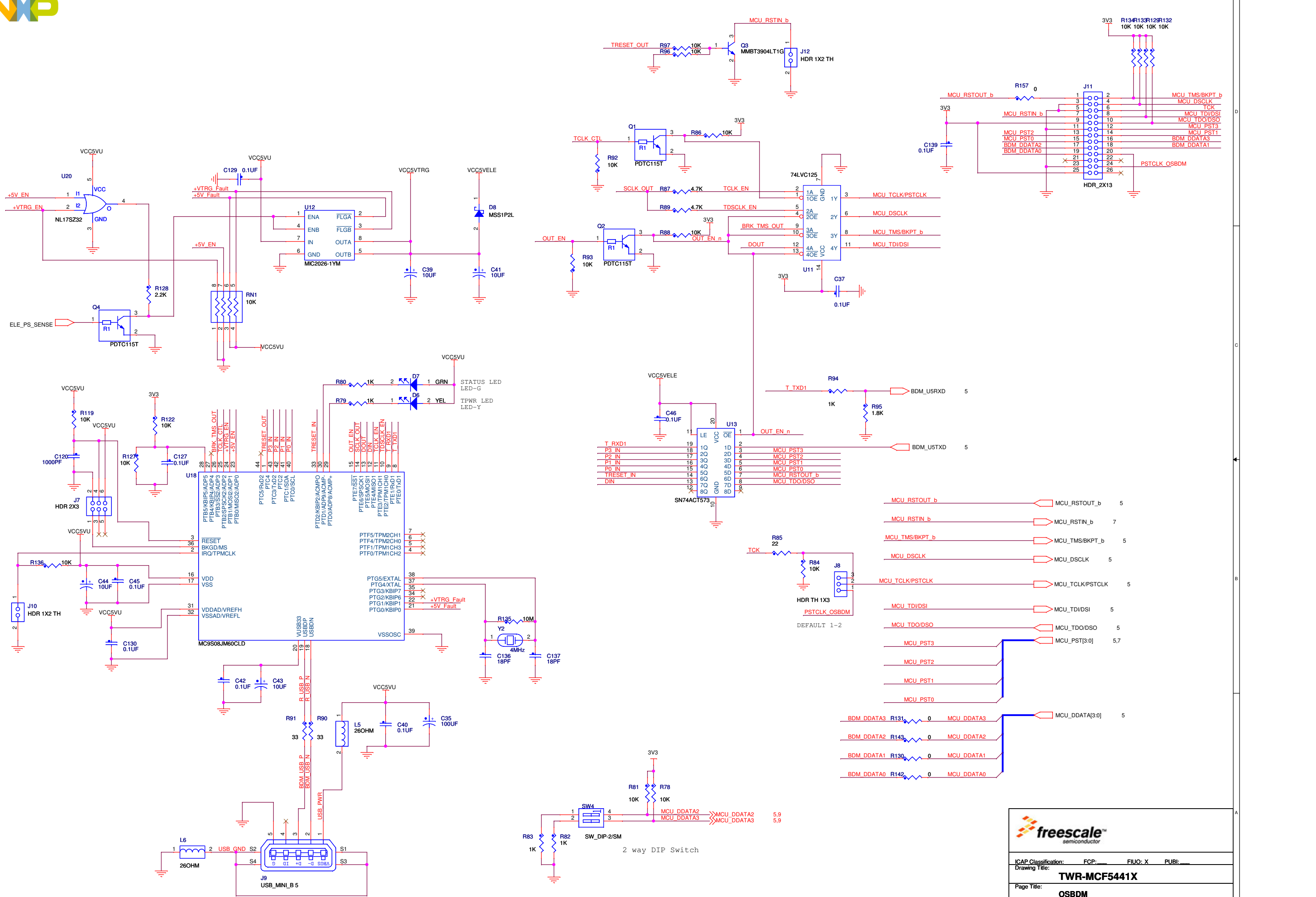

freescale
semiconductor

ICAP Classification: FCP: FIUC: X PUBI:
Drawing Title: **TWR-MCF5441X**
Page Title: **OSBDM**

Size C	Document Number SCH-26131 PDF: SPF-26131	Rev C
Date: Friday, July 23, 2010	Sheet 10 of 11	

