

UM11972

BTS6306U Evaluation Board Quick Start Guide

Rev. 1.1 — 15 April 2024

User manual

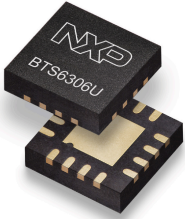

1 Introduction

This document describes the use, design, and test results of the BTS6306U EVB.

1.1 BTS6306U product description

The BTS6306U is a wideband high linearity pre-driver amplifier with differential input for 5G massive MIMO infrastructure applications, with fast on-off switching to support TDD systems. The amplifier is designed to operate between 3.3 GHz and 4.2 GHz. The BTS6306U is housed in a 3 mm x 3 mm x 0.85 mm 16-terminal HVQFN package.

BTS6306U key features and benefits

- High saturated output power $P_{o(sat)} = 28.5$ dBm
- High power-gain $G_p = 38$ dB
- High linearity performance ACLR better than -45 dBc
- Unconditionally stable
- Fast switching to support TDD systems
- 5 V single supply, quiescent current 100 mA
- Small 16-terminal leadless package 3 mm x 3 mm x 0.85 mm
- ESD protection on all terminals
- Moisture sensitivity level 1



1.1 BTS6306U product description...continued

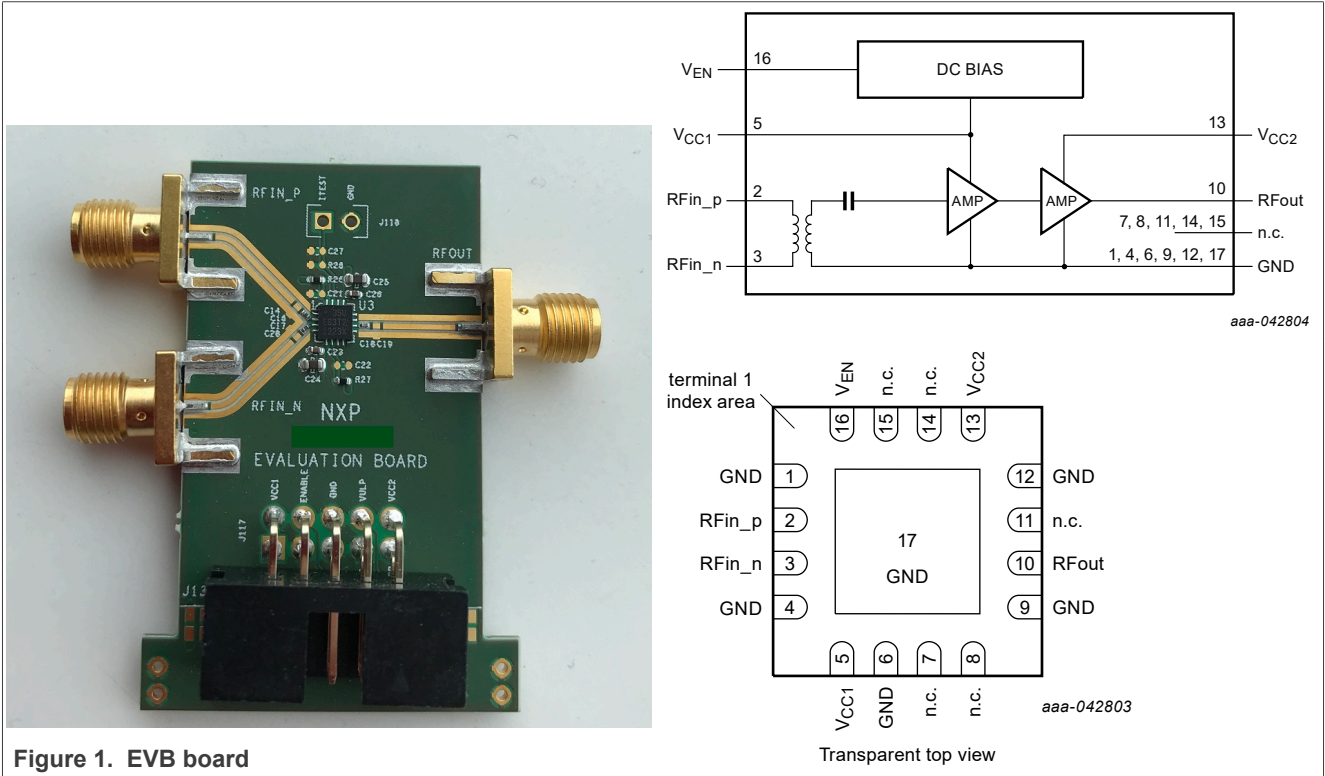
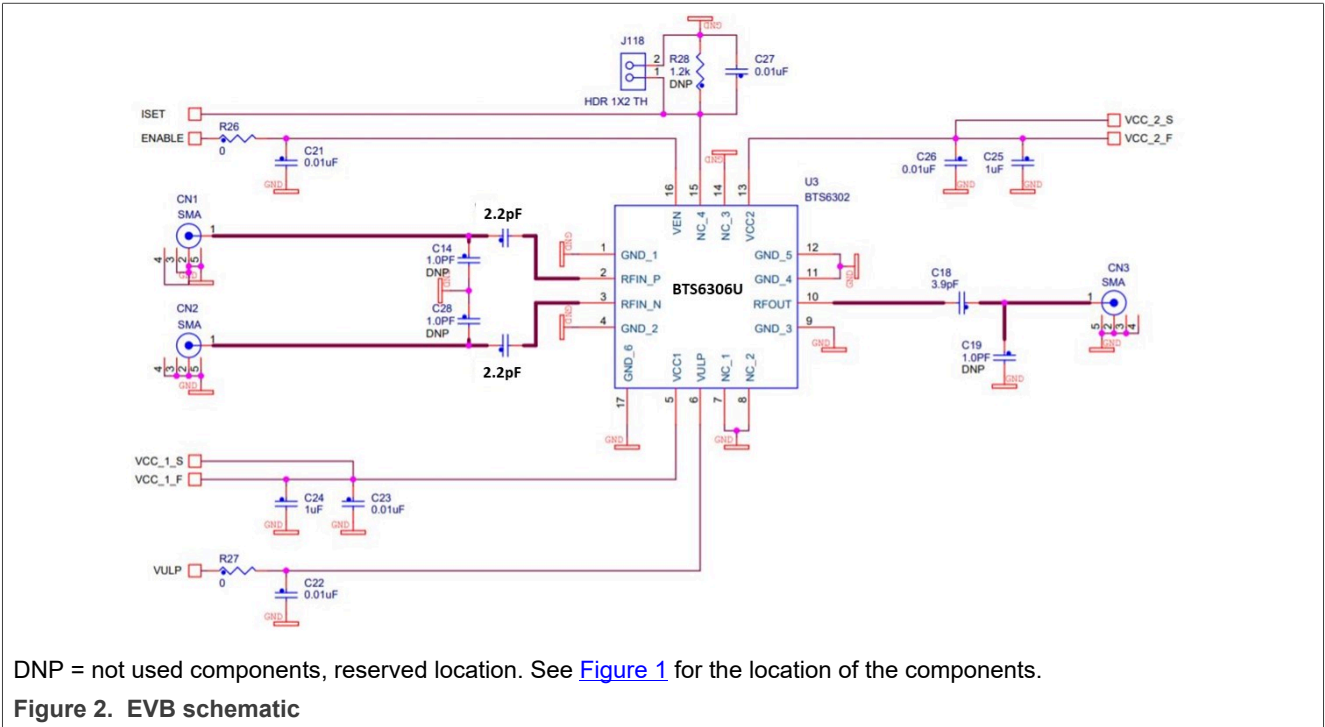

Figure 1. EVB board

2 BTS6306U EVB properties

2.1 Schematic



2.2 DC and control connections

[Figure 3](#) shows the DC and enable connection, at the main header (J117). The connector can be straight or 90 degrees. The text is also on the EVB. [Figure 4](#) shows connectors J118 GND, and J1 ISET. J1 (ISET) on the EVB has no functionality for BTS6306U and should be left open.

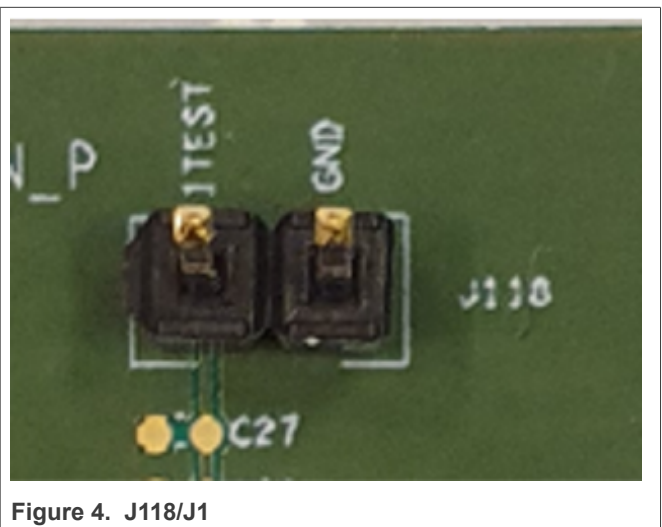
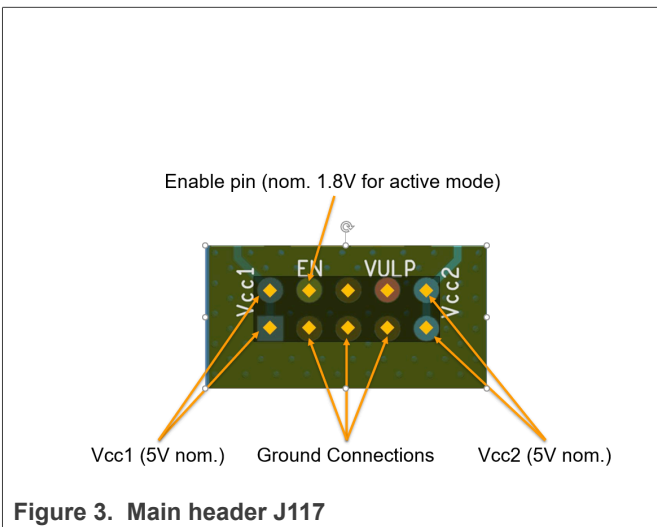

2.3 Operations

Figure 5 shows the connections in a single ended to single ended operation. Figure 6 shows the connections on differential to single ended operation.

If only single ended to single ended operation is needed, NXP refers to UM11646 of the BTS6303U.

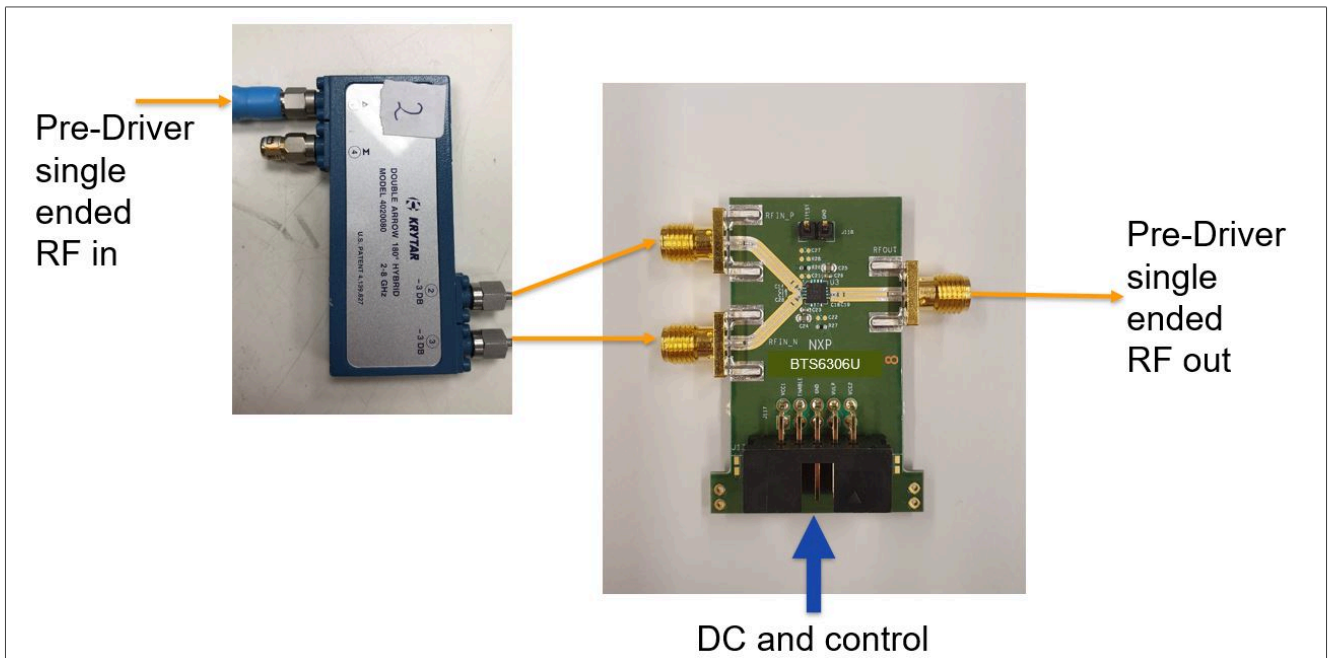

Figure 5. Single ended to single ended operation

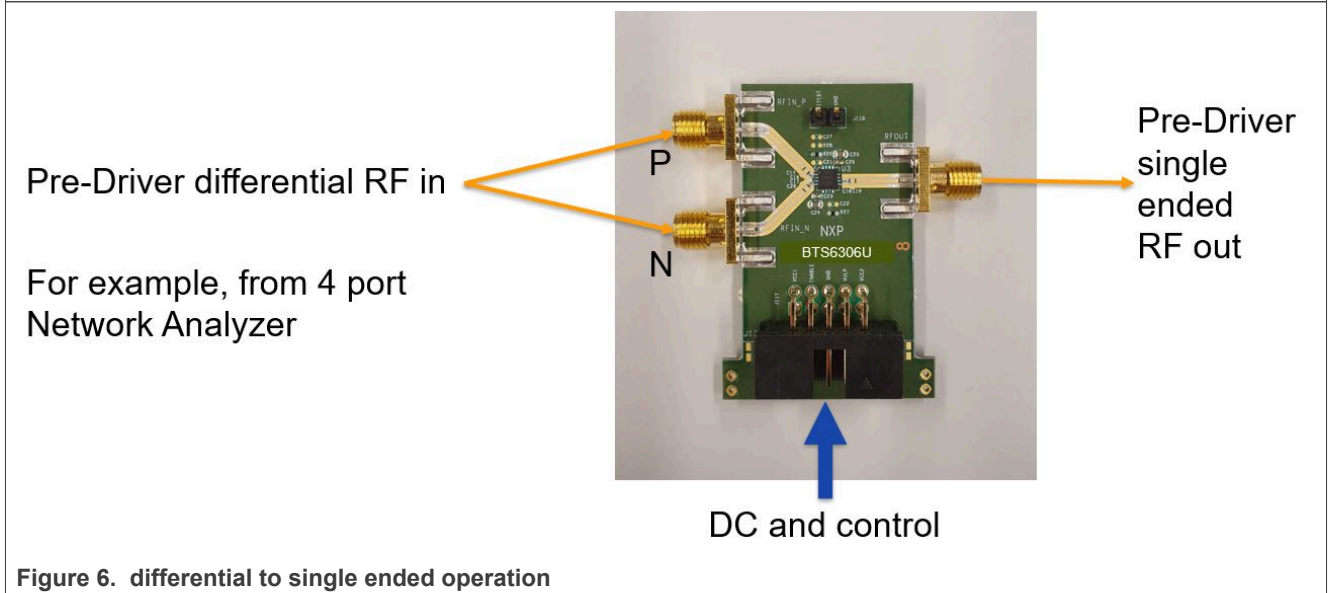

Figure 6. differential to single ended operation

3 Measurements results

In the below graphics, the Spar measurements are shown. Measured at nominal conditions $V_{CC} = 5\text{ V}$, $T_{case} = 25\text{ }^{\circ}\text{C}$.

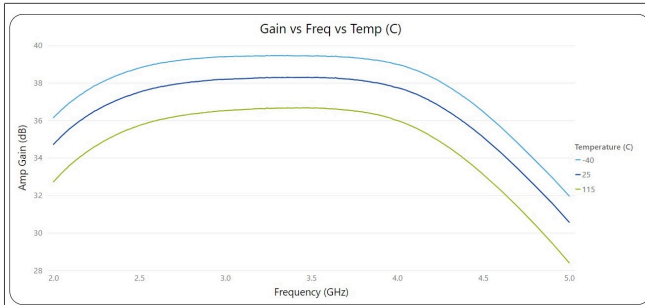

Figure 7. Differential gain at (typical values). $V_{CC} = 5\text{ V}$, $P_i = -25\text{ dBm}$

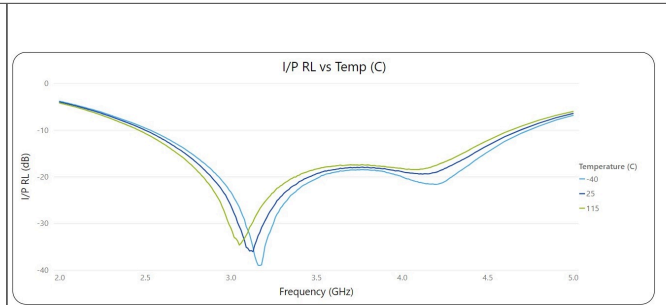

Figure 8. Differential RL_i (typical values). $V_{CC} = 5\text{ V}$, $P_i = -25\text{ dBm}$

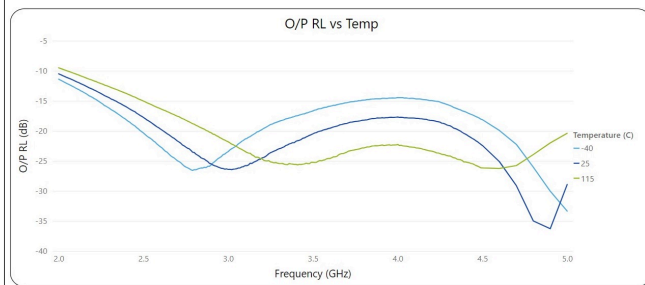

Figure 9. RL_o (typical values). $V_{CC} = 5\text{ V}$, $P_i = -25\text{ dBm}$

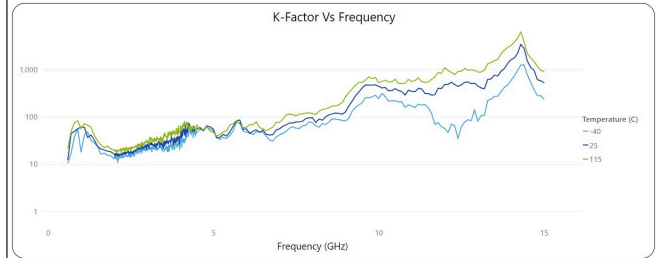

Figure 10. K-factor (typical values). $V_{CC} = 5\text{ V}$, $P_i = -25\text{ dBm}$

4 Abbreviations

Table 1. Abbreviations

| Acronym | Description |
|---------|--|
| ACLR | adjacent channel leakage ratio |
| ESD | electrostatic discharge |
| EVB | evaluation board |
| mMIMO | massive multiple-input multiple-output |
| RF | radio frequency |
| TDD | time-division duplexing |

5 EMC information

CAUTION



This product has not undergone formal EMC assessment. It is the responsibility of the user to ensure that any finished assembly complies with applicable regulations on EMC interference. EMC testing, and other testing requirements for CE is the responsibility of the user.

6 Revision history

Table 2. Revision history

| Document ID | Release date | Description |
|------------------|------------------|---|
| UM11972 Rev. 1.1 | 15 April 2024 | <ul style="list-style-type: none"> Updated Legal information and brought to current standard |
| UM11972 Rev. 1 | 8 September 2023 | <ul style="list-style-type: none"> Initial release of user manual |

Legal information

Definitions

Draft — A draft status on a document indicates that the content is still under internal review and subject to formal approval, which may result in modifications or additions. NXP Semiconductors does not give any representations or warranties as to the accuracy or completeness of information included in a draft version of a document and shall have no liability for the consequences of use of such information.

Disclaimers

Limited warranty and liability — Information in this document is believed to be accurate and reliable. However, NXP Semiconductors does not give any representations or warranties, expressed or implied, as to the accuracy or completeness of such information and shall have no liability for the consequences of use of such information. NXP Semiconductors takes no responsibility for the content in this document if provided by an information source outside of NXP Semiconductors.

In no event shall NXP Semiconductors be liable for any indirect, incidental, punitive, special or consequential damages (including - without limitation - lost profits, lost savings, business interruption, costs related to the removal or replacement of any products or rework charges) whether or not such damages are based on tort (including negligence), warranty, breach of contract or any other legal theory.

Notwithstanding any damages that customer might incur for any reason whatsoever, NXP Semiconductors' aggregate and cumulative liability towards customer for the products described herein shall be limited in accordance with the Terms and conditions of commercial sale of NXP Semiconductors.

Right to make changes — NXP Semiconductors reserves the right to make changes to information published in this document, including without limitation specifications and product descriptions, at any time and without notice. This document supersedes and replaces all information supplied prior to the publication hereof.

Suitability for use — NXP Semiconductors products are not designed, authorized or warranted to be suitable for use in life support, life-critical or safety-critical systems or equipment, nor in applications where failure or malfunction of an NXP Semiconductors product can reasonably be expected to result in personal injury, death or severe property or environmental damage. NXP Semiconductors and its suppliers accept no liability for inclusion and/or use of NXP Semiconductors products in such equipment or applications and therefore such inclusion and/or use is at the customer's own risk.

Applications — Applications that are described herein for any of these products are for illustrative purposes only. NXP Semiconductors makes no representation or warranty that such applications will be suitable for the specified use without further testing or modification.

Customers are responsible for the design and operation of their applications and products using NXP Semiconductors products, and NXP Semiconductors accepts no liability for any assistance with applications or customer product design. It is customer's sole responsibility to determine whether the NXP Semiconductors product is suitable and fit for the customer's applications and products planned, as well as for the planned application and use of customer's third party customer(s). Customers should provide appropriate design and operating safeguards to minimize the risks associated with their applications and products.

NXP Semiconductors does not accept any liability related to any default, damage, costs or problem which is based on any weakness or default in the customer's applications or products, or the application or use by customer's third party customer(s). Customer is responsible for doing all necessary testing for the customer's applications and products using NXP Semiconductors products in order to avoid a default of the applications and the products or of the application or use by customer's third party customer(s). NXP does not accept any liability in this respect.

Terms and conditions of commercial sale — NXP Semiconductors products are sold subject to the general terms and conditions of commercial sale, as published at <https://www.nxp.com/profile/terms>, unless otherwise agreed in a valid written individual agreement. In case an individual agreement is concluded only the terms and conditions of the respective agreement shall apply. NXP Semiconductors hereby expressly objects to applying the customer's general terms and conditions with regard to the purchase of NXP Semiconductors products by customer.

Export control — This document as well as the item(s) described herein may be subject to export control regulations. Export might require a prior authorization from competent authorities.

Suitability for use in non-automotive qualified products — Unless this document expressly states that this specific NXP Semiconductors product is automotive qualified, the product is not suitable for automotive use. It is neither qualified nor tested in accordance with automotive testing or application requirements. NXP Semiconductors accepts no liability for inclusion and/or use of non-automotive qualified products in automotive equipment or applications.

In the event that customer uses the product for design-in and use in automotive applications to automotive specifications and standards, customer (a) shall use the product without NXP Semiconductors' warranty of the product for such automotive applications, use and specifications, and (b) whenever customer uses the product for automotive applications beyond NXP Semiconductors' specifications such use shall be solely at customer's own risk, and (c) customer fully indemnifies NXP Semiconductors for any liability, damages or failed product claims resulting from customer design and use of the product for automotive applications beyond NXP Semiconductors' standard warranty and NXP Semiconductors' product specifications.

Evaluation products — This product is provided on an "as is" and "with all faults" basis for evaluation purposes only. NXP Semiconductors, its affiliates and their suppliers expressly disclaim all warranties, whether express, implied or statutory, including but not limited to the implied warranties of non-infringement, merchantability and fitness for a particular purpose. The entire risk as to the quality, or arising out of the use or performance, of this product remains with customer.

In no event shall NXP Semiconductors, its affiliates or their suppliers be liable to customer for any special, indirect, consequential, punitive or incidental damages (including without limitation damages for loss of business, business interruption, loss of use, loss of data or information, and the like) arising out of the use of or inability to use the product, whether or not based on tort (including negligence), strict liability, breach of contract, breach of warranty or any other theory, even if advised of the possibility of such damages.

Notwithstanding any damages that customer might incur for any reason whatsoever (including without limitation, all damages referenced above and all direct or general damages), the entire liability of NXP Semiconductors, its affiliates and their suppliers and customer's exclusive remedy for all of the foregoing shall be limited to actual damages incurred by customer based on reasonable reliance up to the greater of the amount actually paid by customer for the product or five dollars (US\$5.00). The foregoing limitations, exclusions and disclaimers shall apply to the maximum extent permitted by applicable law, even if any remedy fails of its essential purpose.

Translations — A non-English (translated) version of a document, including the legal information in that document, is for reference only. The English version shall prevail in case of any discrepancy between the translated and English versions.

Security — Customer understands that all NXP products may be subject to unidentified vulnerabilities or may support established security standards or specifications with known limitations. Customer is responsible for the design and operation of its applications and products throughout their lifecycles to reduce the effect of these vulnerabilities on customer's applications and products. Customer's responsibility also extends to other open and/or proprietary technologies supported by NXP products for use in customer's applications. NXP accepts no liability for any vulnerability. Customer should regularly check security updates from NXP and follow up appropriately.

Customer shall select products with security features that best meet rules, regulations, and standards of the intended application and make the ultimate design decisions regarding its products and is solely responsible for compliance with all legal, regulatory, and security related requirements concerning its products, regardless of any information or support that may be provided by NXP.

NXP has a Product Security Incident Response Team (PSIRT) (reachable at PSIRT@nxp.com) that manages the investigation, reporting, and solution release to security vulnerabilities of NXP products.

NXP B.V. — NXP B.V. is not an operating company and it does not distribute or sell products.

Trademarks

Notice: All referenced brands, product names, service names, and trademarks are the property of their respective owners.

NXP — wordmark and logo are trademarks of NXP B.V.

Contents

| | | |
|----------|--------------------------------------|----------|
| 1 | Introduction | 1 |
| 1.1 | BTS6306U product description | 1 |
| 2 | BTS6306U EVB properties | 3 |
| 2.1 | Schematic | 3 |
| 2.2 | DC and control connections | 3 |
| 2.3 | Operations | 4 |
| 3 | Measurements results | 5 |
| 4 | Abbreviations | 6 |
| 5 | EMC information | 6 |
| 6 | Revision history | 6 |
| | Legal information | 7 |

Please be aware that important notices concerning this document and the product(s) described herein, have been included in section 'Legal information'.
