

UM11586

KITVR5510SKTEVM Evaluation Kit User Guideline

Rev. 1 — 3 May 2021

User manual

Document information

Information	Content
Keywords	VR5510, KITVR5510SKTEVM, evaluation kit, automotive, multi-output power management integrated circuit
Abstract	This user manual describes how to use the KITVR5510SKTEVM evaluation kit. The VR5510 is an automotive multi-output power management integrated circuit which focuses on gateway, V2X, and infotainment applications.



Revision history

Rev	Date	Description
v.1	20210503	Initial release
Modifications	NA	

1 Introduction

This document is the user guide for the KITVR5510SKTEVM evaluation boards. This document is intended for engineers involved in the evaluation, design, implementation, and validation of VR5510 Power Management Integrated Circuit (PMIC) for high performance applications.

The scope of this document is to provide the user with information that covers interfacing with the hardware, installing the GUI software, using other tools, and configuring the board for the application environment.

2 Finding Kit Resources and Information on the NXP Web Site

NXP Semiconductors provides online resources for this evaluation board and its supported device(s) on <http://www.nxp.com>.

The information page for KITVR5510SKTEVM evaluation board is at <http://www.nxp.com/KITVR5510SKTEVM>. The information page provides overview information, documentation, software and tools, parametrics, ordering information and a **Getting Started** tab. The **Getting Started** tab provides quick-reference information applicable to using the KITVR5510SKTEVM evaluation board, including the downloadable assets referenced in this document.

2.1 Collaborate in the NXP community

The NXP community is for sharing ideas and tips, ask and answer technical questions, and receive input on just about any embedded design topic.

The NXP community is at <http://community.nxp.com>.

3 Getting Ready

Working with the KITVR5510SKTEVM requires the kit contents, additional hardware and a Windows PC workstation with installed software.

3.1 Kit contents

- Assembled and tested KITVR5510SKTEVM connected to FRDM-K82F in an antistatic bag
- 2.6 ft USB-STD A to USB-B-micro cable
- Quick Start Guide

3.2 Additional hardware

In addition to the kit contents, the following hardware is necessary or beneficial when working with this kit.

- Power supply with a range of 5.0 V to 24.0 V and current limit set initially to 100 mA
- Two power supply cables with banana connectors at one end

3.3 Windows PC workstation

This evaluation board requires a Windows PC workstation. Meeting these minimum specifications should produce great results when working with this evaluation board.

- USB-enabled computer with Windows 7 or Windows 10

3.4 Software

Installing software is necessary to work with this evaluation board. All listed software is available on the evaluation board's information page at <http://www.nxp.com/KITVR5510SKTEVM>.

- NXP_GUI_PR_4.1.0: software interface GUI tool to configure OTP and to generate debug and OTP scripts

4 Getting to Know the Hardware

The KITVR5510SKTEVM evaluation board is the socket programming kit of the VR5510 family of power management ICs from NXP Semiconductors. This section describes the kit features and provides information on the board and its components.

4.1 KITVR5510SKTEVM overview

The KITVR5510SKTEVM is a development platform built around the VR5510 PMIC as the Device Under Test (DUT). The board allows designers to evaluate various functions of the DUT. Connectors on the board provide the capability of measuring power-related functions such as power, efficiency, loop stability, load transients, etc. Jumpers on the board enable the selection of various capabilities, such as I/O control and switching regulator feedback. The EVM also allows the VR5510 to be set into Debug Mode to facilitate the debugging of faults generated by the device.

The KITVR5510SKTEVM includes NXP's FRDM-K82F development platform board. The FRDM-K82F attaches to the bottom of the board and serves as the communication interface between the KITVR5510SKTEVM and GUI software on the PC.

The board contains a socket that allows for the insertion and removal of individual VR5510 devices. This feature—in conjunction with the FRDM-K82Z—enables the One Time Programming of the VR5510 device.

4.1.1 KITVR5510SKTEVM features

The KITVR5510SKTEVM evaluation board offers the following features:

- VR5510 debug mode support
- One Time Programming (OTP) capability for KITVR5510SKTEVM device
- Connectors for measuring:
 - Loop stability
 - Load transients (BUCK12 or VPRE)
 - AMUX/JTAG
 - Signal and power
 - Efficiency
- Load terminals for VPRE, BUCKs, BOOST, LDOs, and HVLDO regulator output
- Jumper selection for:
 - I/O control (RSTB, PGOOD, STANDBY, PWRON2, PSYNC, VDDIO)
 - Debug mode entry/exit
 - Switching regulators (BUCKx, VPRE) feedback
- Multiple test points

4.1.2 Board descriptions

The KITVR5510SKTEVM board provides connectors, jumpers, and test points for all of the evaluation functions supported by the kit. It also contains the socket that enables One Time Programming of the VR5510.

4.1.2.1 LEDs, switches, and sockets

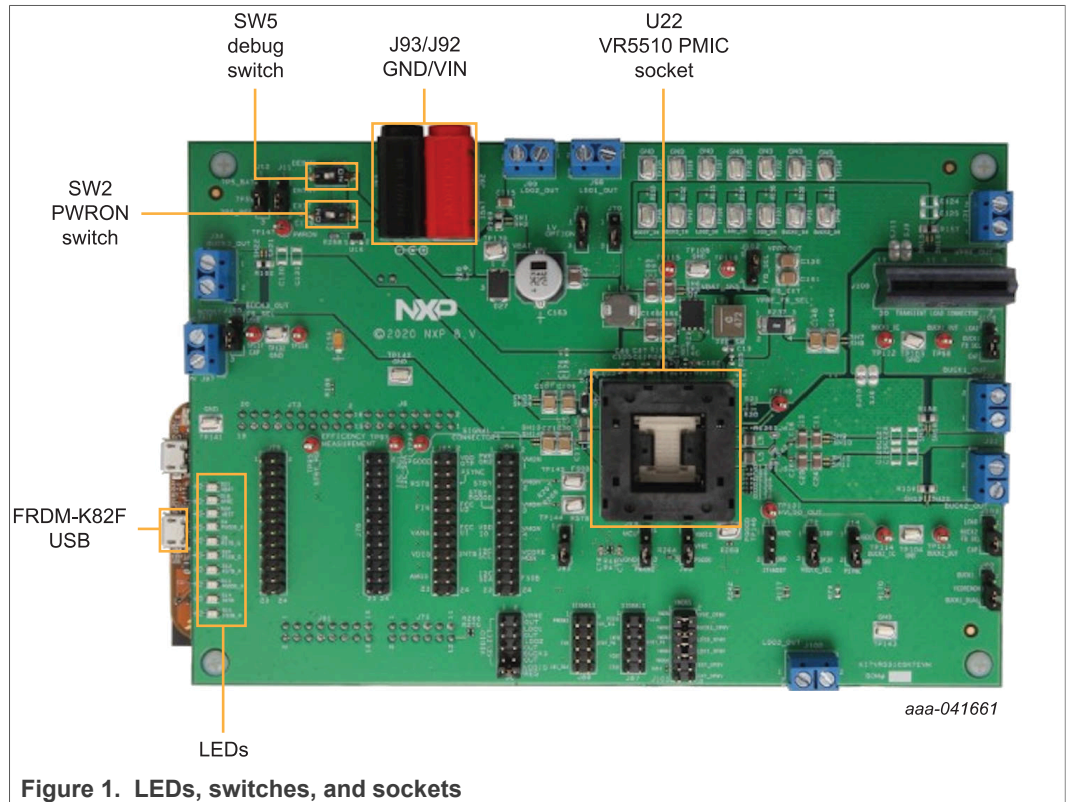

Figure 1. LEDs, switches, and sockets

Table 1. LEDs

Label	Color	Name	Indication
D4	Green	PGOOD_G	External PGOOD signal – PGOOD released
D6	Green	RSTB_G	External RSTB signal – RSTB released
D12	Red	RSTB_R	External RSTB signal – RSTB asserted low
D13	Red	PGOOD_R	External PGOOD signal – PGOOD asserted low
D14	Red	INTB	External INTB signal
D15	Red	FSOB_R	External FSOB signal – FSOB asserted low
D18	Green	VPRE	VPRE_OUT enabled
D20	Green	VBST	BOOST_OUT enabled
D21	Green	VBAT	VBAT on
D29	Green	FSOB_G	External FSOB signal – FSOB released

4.1.2.2 Connectors

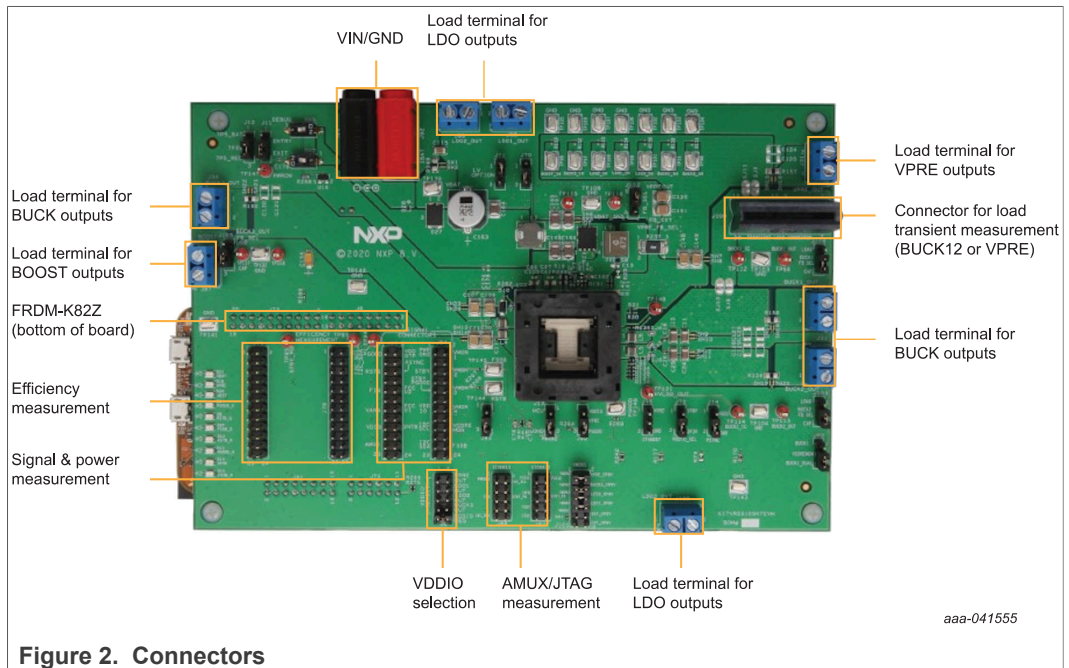

Figure 2. Connectors

Figure 2 shows all of the connectors on the KITVR5510SKTEVM. Pinouts for individual connectors are shown in the schematic.

4.1.2.3 Jumpers

Figure 3 shows the location of jumpers on the KITVR5510SKTEVM board. Table 2 describes the jumper functions and settings.

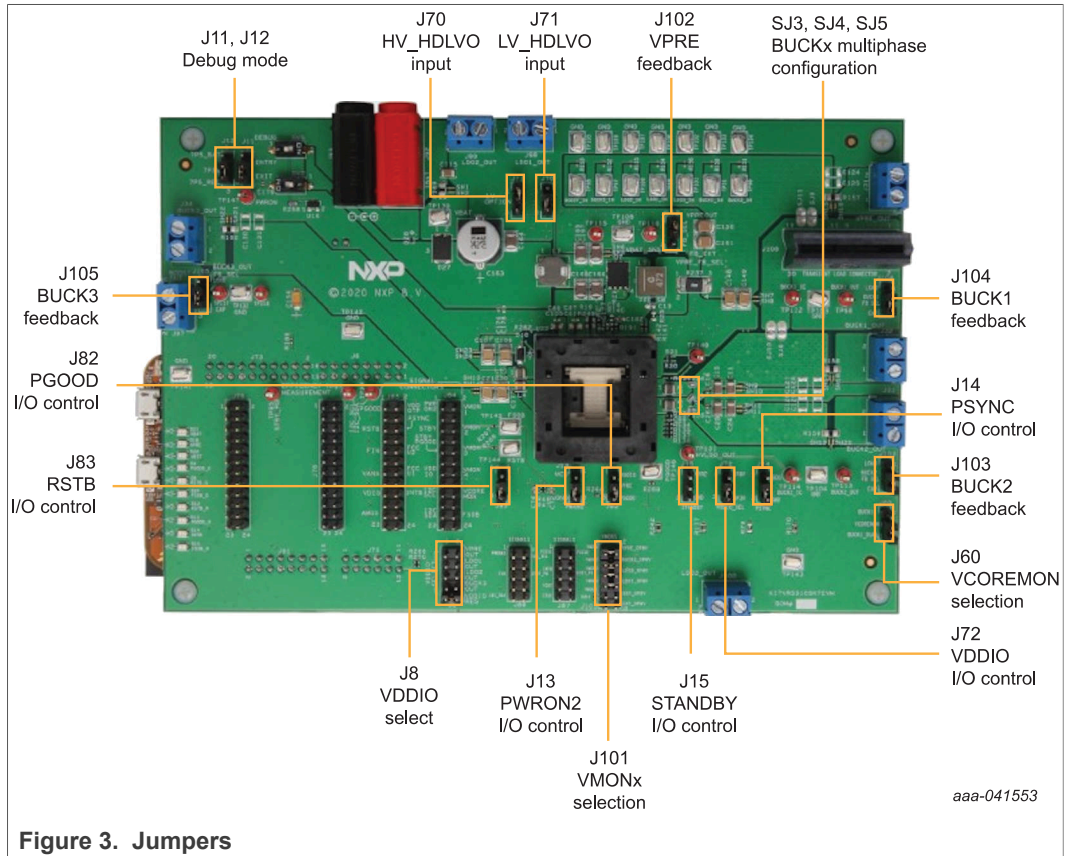

Figure 3. Jumpers

Table 2. Jumpers

Jumper	Function	Position	Description
J8	VDDIO selection	1 – 2 shorted	VPRE
		3 – 4 shorted	LDO1
		5 – 6 shorted	LDO2
		7 – 8 shorted	BUCK3
		9 – 10 shorted (default)	VDDIO external LDO (supplied from FRDM- K82F board)
J11	Debug mode selection	1 – 2 shorted	5 V to debug mode
		2 – 3 shorted (default)	GND to normal mode
J12	Debug mode selection	1 – 2 shorted	7P5V generated from VBAT/VIN directly
		2 – 3 shorted (default)	7P5V generated from an onboard regulator
J13	PWRON2 I/O control	1 – 2 shorted	PWRON2 pin controlled by FRDM-K82F board
		2 – 3 shorted (default)	PWRON2 pin to GND
		open	PWRON2 pin user controlled
J14	PSYNC I/O control	1 – 2 shorted	PSYNC pin pulled up to VBOS
		2 – 3 shorted (default)	PSYNC pin to GND

Table 2. Jumpers...continued

Jumper	Function	Position	Description
		open	PSYNC controlled by FRDM-K82F board
J15	STANDBY I/O control	1 – 2 shorted	STANDBY pin pulled up to VPRE
		2 – 3 shorted	STANDBY pin to GND
		open (default)	STANDBY pin controlled by FRDM-K82F board
J60	VCOREMON source selection	1 – 2 shorted	BUCK1_OUT as VCOREMON input
		2 – 3 shorted (default)	BUCK1/BUCK2_DUAL_PHASE_OUT as VCOREMON input
J70	HDLVO high-voltage input source selection	1 – 2 shorted	VSUP 2 as HV_HDLVO input
		2 – 3 shorted (default)	VPRE_OUT as HV_HDLVO input
J71	HDLVO low-voltage input source selection	1 – 2 shorted (default)	BUCK1_OUT as LV_LDLVO input
		2 – 3 shorted	VPRE as LV_HDLVO input
J72	Voltage setting for VDDIO external regulator (J8: 9–10) selection	1 – 2 shorted	1P8V
		2 – 3 shorted (default)	3P3V
J82	PGOOD pin and pull-up source control	1 – 2 shorted	Pull up to VDDIO
		2 – 3 shorted (default)	Pull up to VPRE
J83	RSTB pin and pull-up source control	1 – 2 shorted	Pull up to VDDIO
		2 – 3 shorted (default)	Pull up to VPRE
J95	Not used	1 – 2 (default open)	
J101	Regx outputs to VMONx (divided down to 0P8V) connection	1 – 2 shorted (default)	VMON1 = VPRE (3.3 V)
		3 – 4 shorted (default)	VMON2 = BUCK3 (1.1 V)
		5 – 6 shorted (default)	VMON3 = LDO2 (1.8 V)
		7 – 8 shorted (default)	VMON4 = LDO1 (1.8 V)
		9 – 10 shorted	VMON4 = BOOST (5 V)
		11 – 12 shorted	VMON4 = External (0.8 V)
J102	VPRE feedback selection	1 – 2 shorted (default)	Feedback from capacitor close to inductor
		2 – 3 shorted	Feedback from external source, if needed
J103	BUCK2 feedback selection	1 – 2 shorted	Feedback from the load
		2 – 3 (default)	Feedback from capacitor close to inductor
J104	BUCK1 feedback selection	1 – 2 shorted	Feedback from the load
		2 – 3 shorted (default)	Feedback from capacitor close to inductor
J105	BUCK3 feedback selection	1 – 2 shorted	Feedback from the load
		2 – 3 shorted (default)	Feedback from capacitor close to inductor
SJ3	BUCK1/BUCK2 Multiphase configuration	open (default)	BUCK1/BUCK2 in Single Phase
		shorted	BUCK1/BUCK2 in Dual Phase

Table 2. Jumpers...continued

Jumper	Function	Position	Description
SJ4	BUCK1 Single/ Multiphase configuration	open	
		shorted (default)	BUCK1 in both Single and Multiphase
SJ5	BUCK2 Single/ Multiphase configuration	open	
		shorted (default)	BUCK2 in both Single and Multiphase

4.1.2.4 Test points

Figure 4 shows the location and the function of the test points on the KITVR5510SKTEVM board

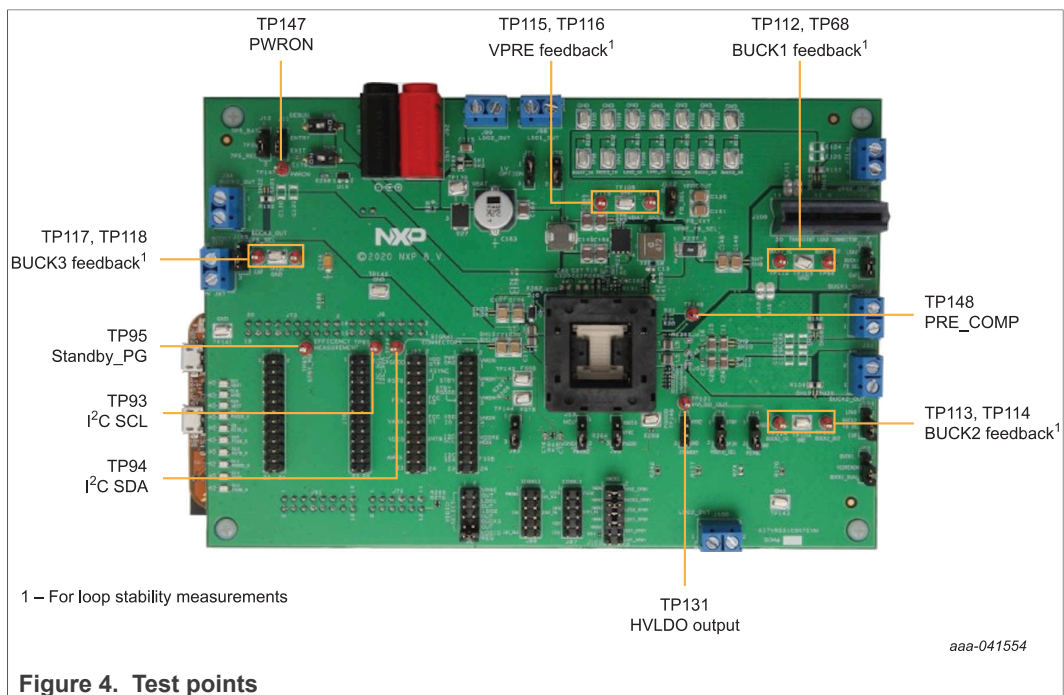

Figure 4. Test points

4.1.3 Layout

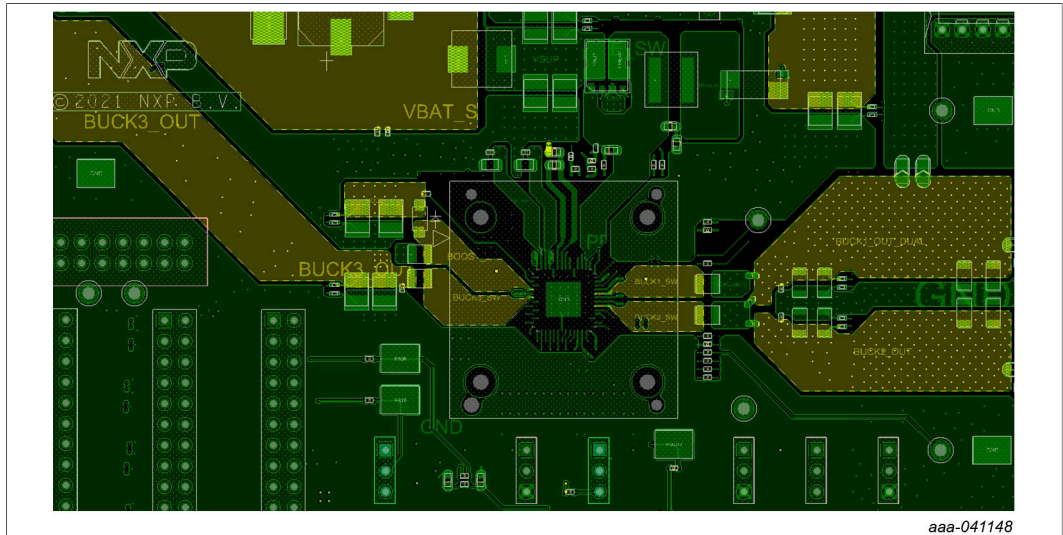

Figure 5. KITVR5510SKTEVM layout – top

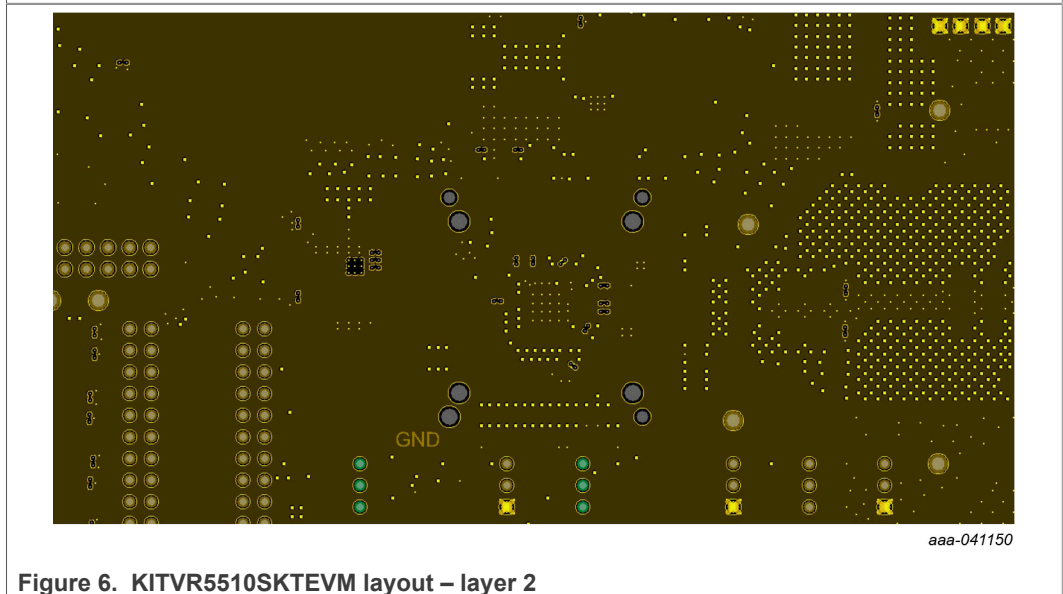

Figure 6. KITVR5510SKTEVM layout – layer 2

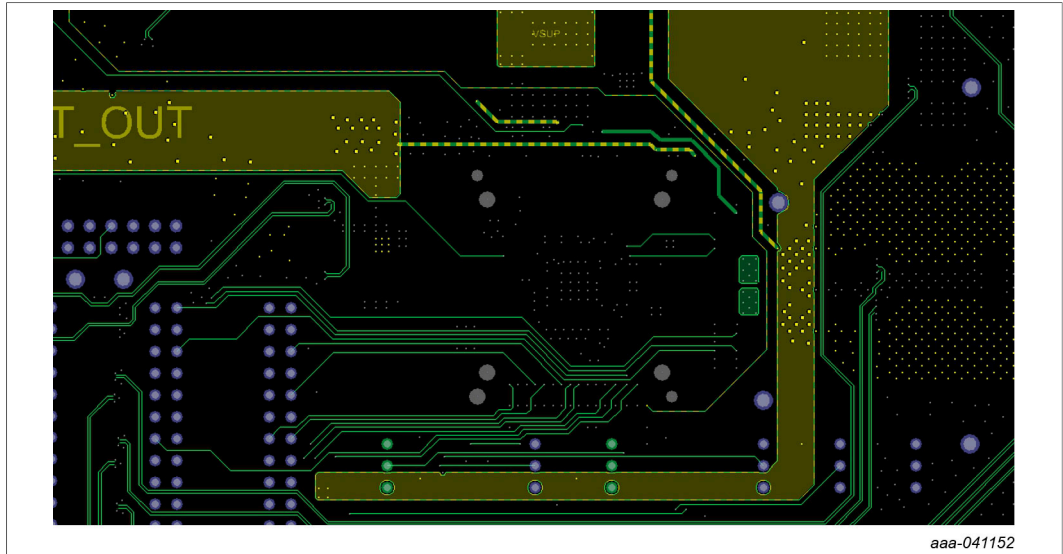

Figure 7. KITVR5510SKTEVM layout – layer 3

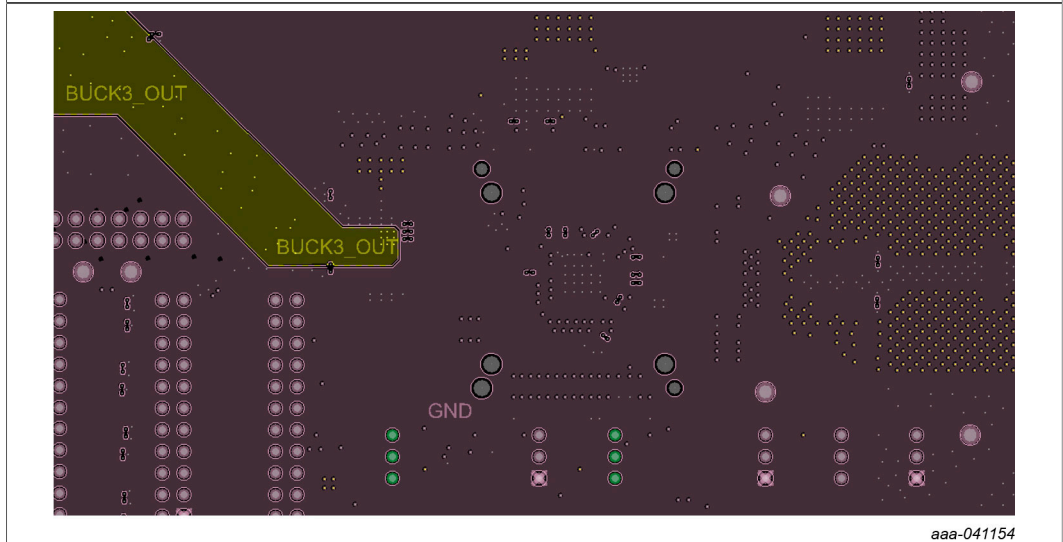
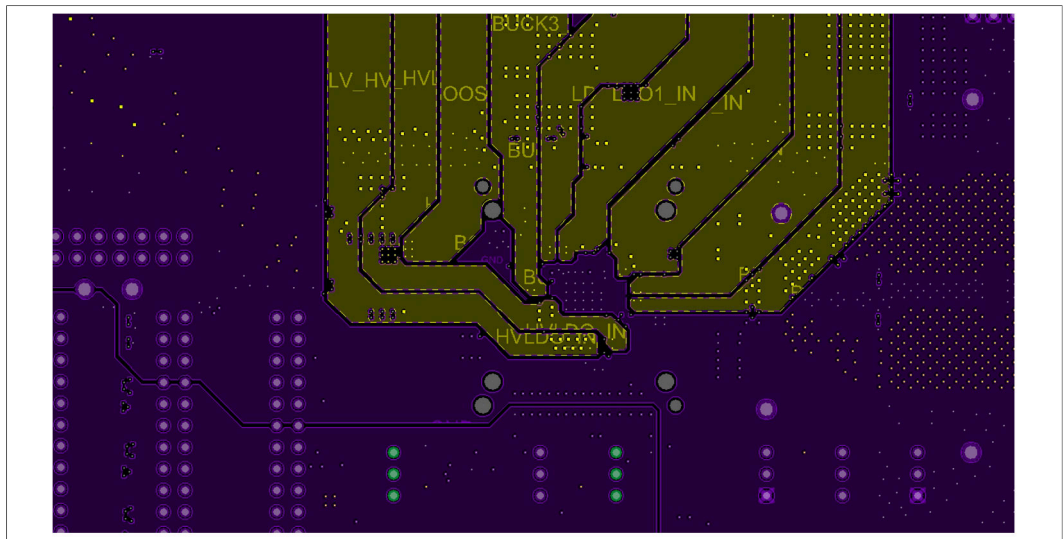
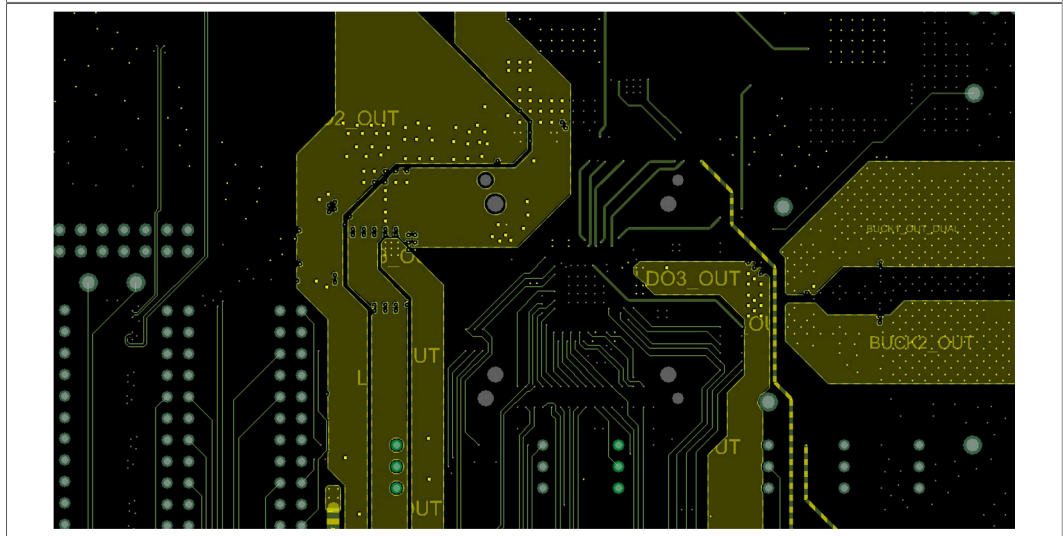

Figure 8. VR5510SKTEVM layout – layer 4



aaa-041156

Figure 9. KITVR5510SKTEVM layout – layer 5



aaa-041158

Figure 10. KITVR5510SKTEVM layout – layer 6

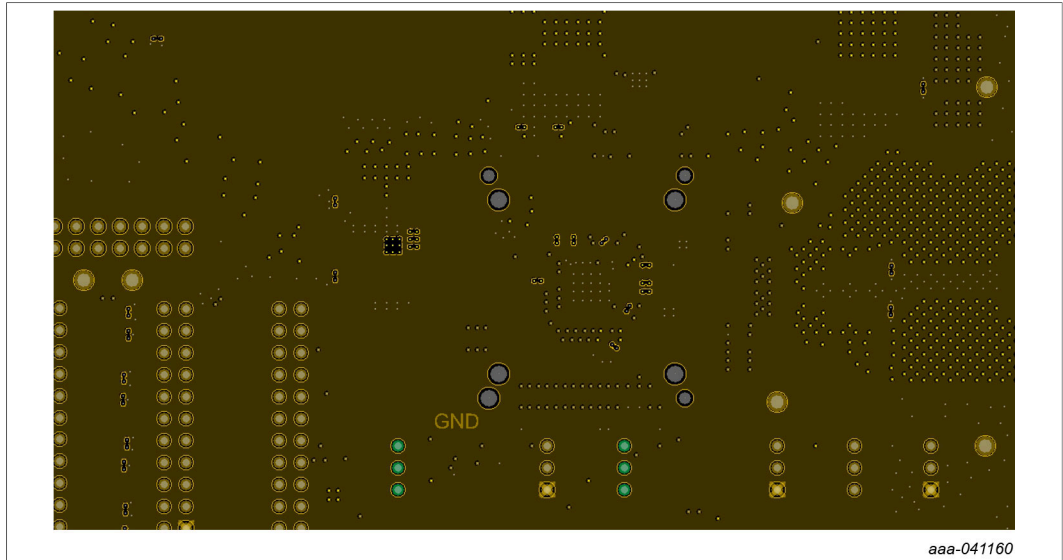

Figure 11. KITVR5510SKTEVM layout – layer 7

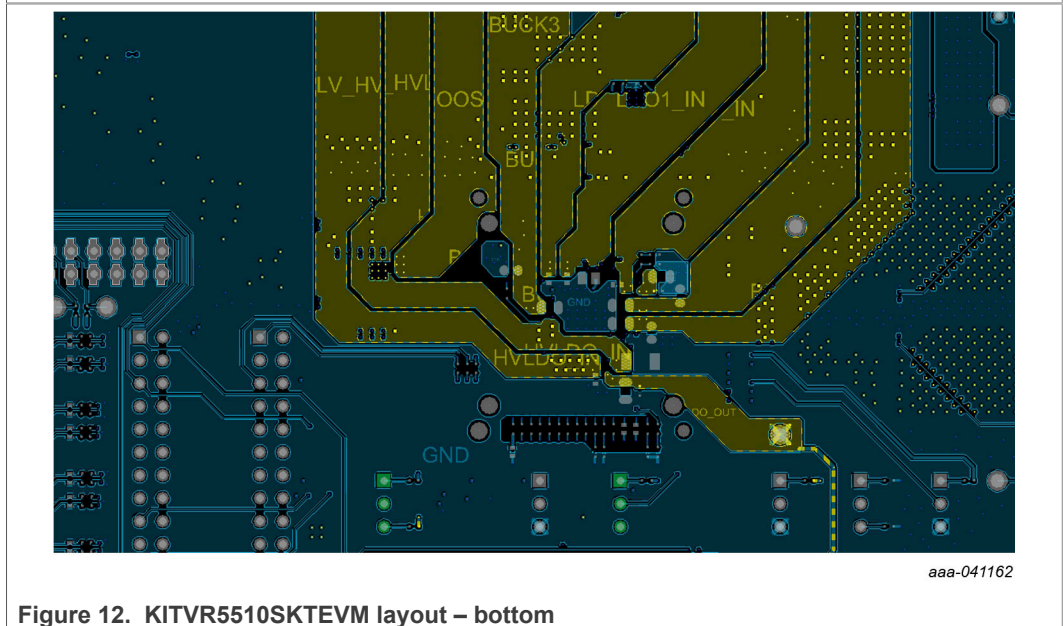

Figure 12. KITVR5510SKTEVM layout – bottom

4.1.4 Bill of Materials

Table 3. Bill of Materials

NXP does not assume liability, endorse, or warrant components from external manufacturers that are referenced in circuit drawings or tables. While NXP offers component recommendations in this configuration, it is the customer's responsibility to validate their application.

DNP: do not populate

For critical components, it is vital to use the manufacturer listed.

Quantity	Schematic label	Value	Description	Part number	Manufacturer name	Assy Opt
Active components						
1	U16	250 mW, 7.5 V	DIODE ZENER 7.5 V 250 mW AEC-Q101 SOT23	BZX84-A7V5	Nexperia	
1	U17	1.5-15 V 150 mA 2.5-16 V	IC LIN VREG LDO 1.5-15 V 150 mA 2.5-16 V SOT23-5	MIC5205YM5	MICREL	
1	U20	1.25 V-60 V 50 mA 4.5-60 V	IC LIN VREG ADJ 1.25 V-60 V 50 mA 4.5-60 V SOP-8	RT9068GSP	RICHTEK	
1	U22		SUBASSEMBLY SKT 56 COMPRESSION QFN SMT 0.5MM 577H -- + IC PWR MANAGEMENT -0.3-5.5V QFN56		VISHAY INTERTECHNOLOGY	
Capacitors						

Table 3. Bill of Materials...continued

NXP does not assume liability, endorse, or warrant components from external manufacturers that are referenced in circuit drawings or tables. While NXP offers component recommendations in this configuration, it is the customer's responsibility to validate their application.

DNP: do not populate

For critical components, it is vital to use the manufacturer listed.

Quantity	Schematic label	Value	Description	Part number	Manufacturer name	Assy Opt
4	C11,C15,C24,C25	22 µF	CAP CER 22 µF 10 V 10% X7R AEC-Q200 1206	GCM31CR71A226KE02	MURATA	
1	C115	47 µF	CAP CER 47 µF 10 V 20% X5R AEC-Q200 1206	GRT31CR61A476ME13L	MURATA	
3	C121,C122,C123	1000 pF	CAP CER 1000 pF 50 V 10% X7R AEC-Q200 0603	CGA3E2X7R1H102K080AA	TDK	DNP
8	C124,C125,C126,C127,C128,C129,C130,C131	22 µF	CAP CER 22 µF 10 V 10% X7R AEC-Q200 1206	GCM31CR71A226KE02	MURATA	DNP
1	C13	2200 pF	CAP CER 2200 pF 50 V 10% X7R 0603	C0603X7R500-222KNE	VENKEL COMPANY	DNP
1	C132	470 pF	CAP CER 470 pF 50 V 5% C0G 0603	CC0603JRNPO9BN471	YAGEO AMERICA	
4	C133,C134,C135,C136	22 pF	CAP CER 22 pF 50 V 1% C0G 0402	04025A220FAT2A	AVX	DNP
1	C14	1000 pF	CAP CER 1000 pF 50 V 10% X7R AEC-Q200 0402	GCM155R71H102KA37D	MURATA	DNP
1	C153	4.7 µF	CAP CER 4.7 µF 10 V 10% X7S AEC-Q200 0805	GCM21BC71A475KA73	MURATA	
1	C156	2.2 µF	CAP TANT ESR=1.800 ΩS 2.2 µF 10 V 10% 3216-18	TPSA225K010R1800	AVX	
9	C16,C17,C26,C66,C67,C94,C102,C176,C177	0.1 µF	CAP CER 0.1 µF 50 V 10% X7R AEC-Q200 0402	GCM155R71H104KE02	MURATA	
1	C162	0.047 µF	CAP CER 0.047 µF 50 V 10% X7R AEC-Q200 0603	CGA3E2X7R1H473K080AA	TDK	
1	C163	47 µF	CAP ALEL 47 µF 50 V 20% AEC-Q200 SMD	MAL214699101E3	VISHAY INTERTECHNOLOGY	
5	C164,C165,C166,C167,C168	10 µF	CAP CER 10 µF 50 V 10% X7S AEC-Q200 1210	CGA6P3X7S1H106K250AB	TDK	
1	C172	1 µF	CAP CER 1 µF 25 V 10% X7R AEC-Q200 0603	CGA3E1X7R1E105K080AC	TDK	
1	C173	0.22 µF	CAP CER 0.22 µF 50 V 10% X7R 0805	C0805X7R500-224KNE	VENKEL COMPANY	
1	C178	330 pF	CAP CER 330 pF 50 V 5% C0G AEC-Q200 0402	GCM1555C1H331JA16D	MURATA	DNP
2	C179,C180	0.022 µF	CAP CER 0.022 µF 50 V 10% X7R AEC-Q200 0402	GCM155R71H223KA55D	MURATA	
1	C181	18 pF	CAP CER 18 pF 50 V 5% C0G AEC-Q200 0402	GCM1555C1H180JA16	MURATA	
6	C19,C23,C104,C105,C108,C110	4.7 µF	CAP CER 4.7 µF 16 V 10% X7R AEC-Q200 0805	GCM21BR71C475KA73	MURATA	
8	C20,C21,C106,C107,C148,C149,C150,C161	22 µF	CAP CER 22 µF 16 V 20% X7R AEC-Q200 1210	GCM32ER71C226ME19	MURATA	
1	C61	10 µF	CAP CER 10 µF 16 V 20% X7S AEC-Q200 0805	CGA4J1X7S1C106M125AC	TDK	
3	C69,C113,C154	1000 pF	CAP CER 1000 pF 50 V 10% X7R AEC-Q200 0402	GCM155R71H102KA37D	MURATA	
1	C71	0.01 µF	CAP CER 0.01 µF 50 V 10% X7R AEC-Q200 0402	GCM155R71H103KA55D	MURATA	DNP
1	C72	0.01 µF	CAP CER 0.01 µF 50 V 5% X7R 0603	C0603C103J5RACTU	KEMET	
2	C155,C174	1 µF	CAP CER 1 µF 16 V 10% X6S 0402	GRM155C81C105KE11D	MURATA	
1	C76	0.022 µF	CAP CER 0.022 µF 25 V 10% X7R 0603	CC0603KRX7R8BB223	YAGEO AMERICA	
17	C95,C96,C97,C98,C100,C112,C137,C138,C139,C140,C141,C142,C143,C144,C145,C146,C147,C160	1 µF	CAP CER 1 µF 10 V 10% X7S AEC-Q200 0402	GCM155C71A105KE38D	MURATA	
1	C99	1.0 µF	CAP CER 1.0 µF 50 V 10% X7R FAIL SAFE AEC-Q200 1206	GCJ31CR71H105KA12L	MURATA	
Diodes						
1	D10	2 A	DIODE SCH PWR RECT 2 A 60V AEC-Q101 SOD-123	NRVTS260ESFT1G	ON SEMICONDUCTOR	
4	D12,D13,D14,D15	20 mA	LED RED SGL 20 mA SMT	LS M67K-H2L1-1-0-2-R18-Z	OSRAM	
1	D27	5 A	DIODE SCH RECT 60 V 5 A AEC-Q101 SOT1289	PMEG060V050EPD	Nexperia	
1	D28	36 V	DIODE TVS UNIDIR 36 V -- AEC-Q101 SOD882	AQHV36-01ETG	LITTELFUSE	
6	D4,D6,D18,D20,D21,D29	2 Ma	LED GRN SGL 2 0mA SMT NRND	LP M67K-E2G1-25	OSRAM	
Resistors						
1	R143	470 KΩ	RES TF 470 KΩ 1/10 W 1% AEC-Q200 0402	ERJ-2RKF4703X	PANASONIC	
5	R149,R157,R158,R159,R160	0.01 Ω	RES TF 0.01 Ω 1 W 1% AEC-Q200 1206	ERJ-8CWF010V	PANASONIC	
9	R15,R20,R85,R86,R87,R219,R225,R228,R265	1.50 KΩ	RES MF 1.50 KΩ 1/16 W 1% 0402	WR04X1501FTL	WALSIN TECHNOLOGY CORP.	
1	R169	68.1 KΩ	RES MF 68.1 KΩ 1/10 W 1% 0603	CRCW060368K1FKEA	VISHAY INTERTECHNOLOGY	
3	R17,R21,R220	510 KΩ	RES MF 510 KΩ 1/10 W 5% 0603	RC0603JR-07510KL	YAGEO AMERICA	
2	R170,R242	27.4 KΩ	RES MF 27.4 KΩ 1/10 W 1% 0603	RC0603FR-0727K4L	YAGEO AMERICA	

Table 3. Bill of Materials...continued

NXP does not assume liability, endorse, or warrant components from external manufacturers that are referenced in circuit drawings or tables. While NXP offers component recommendations in this configuration, it is the customer's responsibility to validate their application.

DNP: do not populate

For critical components, it is vital to use the manufacturer listed.

Quantity	Schematic label	Value	Description	Part number	Manufacturer name	Assy Opt
1	R177	115.0 KΩ	RES MF 115.0 KΩ 1/10 W 1% AEC-Q200 0603	RK73H1JTTD1153F	KOA SPEER	
1	R180	68.1 KΩ	RES MF 68.1 KΩ 1/10 W 1% 0603	CRCW060368K1FKEA	VISHAY INTERTECHNOLOGY	DNP
1	R188	169 KΩ	RES MF 169 KΩ 1/10 W 1% AEC-Q200 0402	RK73H1ETTP1693F	KOA SPEER	
1	R189	280 KΩ	RES MF 280 KΩ 1/10 W 1% AEC-Q200 0402	RK73H1ETTP2803F	KOA SPEER	
3	R19,R248,R272	ZERO Ω	RES MF ZERO Ω 1/10 W -- 0603	CR-03JL7----0R	THYE MING TECH CO LTD	
1	R190	76.8 KΩ	RES MF 76.8 KΩ 1/10 W 1% AEC-Q200 0402	RK73H1ETTP7682F	KOA SPEER	
22	R192,R193,R194,R195,R196,R197,R198,R199,R200,R201,R202,R203,R204,R205,R206,R207,R208,R209,R210,R211,R212,R213	1 KΩ	RES MF 1 KΩ 1/16 W 0.1% 0402	RN731ETTP1001B25	KOA SPEER	
9	R2,R46,R47,R145,R217,R218,R229,R254,R266	5.1 KΩ	RES 5.1 KΩ 1/16 W 0.1% 0402	ERA2AEB512X	PANASONIC	
1	R237	0.01 Ω	RES METAL STRIP 0.01 Ω 1 W 1% 2512	WSK2512R0100FEA	VISHAY INTERTECHNOLOGY	
1	R25	2.2 Ω	RES MF 2.2 Ω 1/10W 1% AEC-Q200 0603	CRCW06032R20FKEA	VISHAY INTERTECHNOLOGY	DNP
1	R251	620 KΩ	RES MF 620 KΩ 1/10 W 1% AEC-Q200 0402	RK73H1ETTP6203F	KOA SPEER	
1	R252	115 KΩ	RES MF 115 KΩ 1/10 W 1% AEC-Q200 0402	RK73H1ETTP1153F	KOA SPEER	
1	R258	1.00 KΩ	RES MF 1.00 KΩ 1/10 W 0.1% AEC-Q200 0603	ERA3AEB102V	PANASONIC	
1	R259	10 KΩ	RES MF 10 KΩ 1/10 W 0.1% AEC-Q200 0603	ERA-3AEB103V	PANASONIC	
2	R26,R27	1.0 MΩ	RES MF 1.0 MΩ 1/16 W 1% AEC-Q200 0402	RK73H1ETTP1004F	KOA SPEER	
1	R260	100 KΩ	RES MF 100 KΩ 1/10 W 5% AEC-Q200 0603	CRCW0603100KJNEA	VISHAY INTERTECHNOLOGY	
2	R263,R264	1.8 KΩ	RES MF 1.8 KΩ 1/10 W 1% AEC-Q200 0402	RK73H1ETTP1801F	KOA SPEER	
1	R271	1.5 KΩ	RES MF 1.5 KΩ 1/16 W 0.1% AEC-Q200 0402	ERA-2AEB152X	PANASONIC	
1	R29	5.1 K Ω	RES 5.1 K Ω 1/16 W 0.1% 0402	ERA2AEB512X	PANASONIC	DNP
1	R30	ZERO Ω	RES MF ZERO Ω 1/16 W -- AEC-Q200 0402	CRCW04020000Z0ED	VISHAY INTERTECHNOLOGY	DNP
56	R31,R116,R117,R118,R119,R120,R121,R122,R123,R124,R125,R126,R127,R128,R129,R130,R131,R132,R133,R134,R135,R136,R137,R138,R139,R140,R141,R142,R150,R151,R152,R153,R154,R155,R156,R161,R167,R171,R174,R178,R182,R183,R184,R185,R186,R187,R191,R232,R233,R256,R261,R262,R267,R268,R269,R270	ZERO Ω	RES MF ZERO Ω 1/16 W -- AEC-Q200 0402	CRCW04020000Z0ED	VISHAY INTERTECHNOLOGY	
4	R36,R146,R147,R148	10 KΩ	RES MF 10 KΩ 1/16 W 1% 0402	RC0402FR-0710KL	Yageo	
2	R38,R238	2.2 KΩ	RES MF 2.2 KΩ 1/16 W 1% AEC-Q200 0402	CRCW04022K20FKED	VISHAY INTERTECHNOLOGY	
1	R64	8.2 KΩ	RES MF 8.2 KΩ 1/10 W 1% AEC-Q200 0402	RK73H1ETTP8201F	KOA SPEER	
1	R79	115.0 KΩ	RES MF 115.0 KΩ 1/10 W 1% AEC-Q200 0603	RK73H1JTTD1153F	KOA SPEER	DNP
5	R88,R168,R172,R175,R179	22.1 KΩ	RES MF 22.1 KΩ 1/10 W 1% 0603	CRCW060322K1FKEA	VISHAY INTERTECHNOLOGY	
Switches, Connectors, Jumpers, and Test Points						
1	J101	HDR 2X6	HDR 2X6 TH 100MIL CTR 338H AU 100L	TSW-106-07-F-D	SAMTEC	
1	J106	CON 2X10	CON 2X10 POWER EDGE TH 2.5MM SP 600H AU 115L	45719-0007	MOLEX	
1	J11,J12,J13,J14,J15,J60	HDR 1x3	HDR 1x3 TH 100MIL SP 343H SN 100L	TSW-103-07-T-S	SAMTEC	
8	J31,J32,J33,J34,J97,J98,J99,J100	CON 1X2	CON 1X2 TB TH 5MM SP 398H SN 138L	691102710002	WURTH ELEKTRONIK EISOS GMBH & CO. KG (ELECTRONIC & ELECTROMECHANICAL COMP)	
2	J6,J91	CON 2X8	CON 2X8 PLUG 2.54MM CTR 328H AU 120L	5-146257-8	TE Connectivity Ltd	
9	J70,J71,J72,J82,J83,J102,J103,J104,J105	HDR 1X3	HDR 1X3 TH 100MIL SP 330H AU	HTSW-103-07-S-S	SAMTEC	
1	J73	CON 2X10	CON 2X10 PLUG 2.54MM CTR 328H AU 120L	6-146257-0	TE Connectivity Ltd	
1	J75	CON 2X6	CON 2X6 PLUG 2.54MM CTR 328H AU 120L	5-146257-6	TE Connectivity Ltd	
14	J76,J78,J84,J85	HDR 2X12	HDR 2X12 TH 100MIL CTR 338H AU 100L	TSW-112-07-G-D	SAMTEC	
1	J8	HDR 2X5	HDR 2X5 TH 100MIL CTR 339H AU 95L	210-92-05GB01	Pinrex Enterprise Co., Ltd	
2	J86,J87	HDR 2X5	HDR 2X5 TH 100mil CTR 330H Au	TSW-105-08-G-D	SAMTEC	
1	J92	CON 1X2	CON 1X2 BANANA RED RA TH 15.3MM SP 488H AG 197L	571-0500	DELTRON EMCON LTD	
1	J93	CON 1X2	CON 1X2 BANANA BLACK RA TH 15.3MM SP 488H AG 197L	571-0100	DELTRON EMCON LTD	
1	J95	HDR 1X2	HDR 1X2 TH 100MIL SP 378H AU 130L	826629-2	TYCO ELECTRONICS	
1	L11	4.7 μH	IND PWR 4.7 μH@1 MHz 2.2A 20% AEC-Q200 SMD	TFM252012ALMA4R7MTAA	TDK	
1	L2	1.0 μH	IND PWR 1.0 μH@ 100KHz 17.9A 20% AEC-Q200 SMD	SPM6545VT-1R0M-D	TDK	

Table 3. Bill of Materials...continued

NXP does not assume liability, endorse, or warrant components from external manufacturers that are referenced in circuit drawings or tables. While NXP offers component recommendations in this configuration, it is the customer's responsibility to validate their application.

DNP: do not populate

For critical components, it is vital to use the manufacturer listed.

Quantity	Schematic label	Value	Description	Part number	Manufacturer name	Assy Opt
3	L4,L5,L6	1.0 μ H	IND PWR 1.0 μ H@1 MHz 4.7A 20% AEC-Q200 SMD	TFM252012ALMA1R0 MTAA	TDK	
1	L7	4.7 μ H	IND PWR 4.7 μ H@100 kHz 11A 20% AEC-Q200 SMT	XAL6060-472ME	COILCRAFT	
3	Q4,Q5,Q10	30 V 400 mA	TRAN NMOS PWR 30 V 400 mA AEC-Q101 SOT23	NX3008NBK,215	Nexperia	
1	Q7	16.8 m Ω 49 A 60 V	TRAN NMOS DUAL PWR 16.8 m Ω 49 A 60 V AEC-Q101 SO8FL	NVMFD5C672NL	ON SEMICONDUCTOR	
1	Q9	-20 VDS	TRAN PMOS PWR -20VDS SOT-23	IRLML6302TRPBF	INTERNATIONAL RECTIFIER	
22	SH1,SH2,SH5,SH6,SH7,SH8,SH9,SH10,SH11, SH12,SH13,SH14,SH15,SH16,SH17,SH18,S H19,SH20,SH21,SH22,SH23,SH24	0 Ω	ZERO OHM CUT TRACE 0201 PADS; NO PART TO ORDER			
3	SJ3,SJ4,SJ5		SOLDER BLOB JUMPER 0402 OPEN NO PART TO ORDER			
4	SJ8,SJ9,SJ10,SJ11		SOLDER BLOB JUMPER 1206 OPEN NO PART TO ORDER			
2	SW2,SW5		SW SPST DIP SLD 25 mA 24 V SMD	A6S-1104-H	OMRON	
2	TP119,TP120		TEST POINT PAD 30 MIL DIA SMT, NO PART TO ORDER			
25	TP51,TP96,TP97,TP98,TP99,TP100,TP101,TP 102,TP103,TP104,TP105,TP106,TP107,TP108 ,TP109,TP130,TP132,TP133,TP134,TP141,TP 142,TP143,TP144,TP145,TP146		TEST POINT PAD SIZE 4.7 MM X 3.4 MM SMT	5016	KEYSTONE ELECTRONICS	
14	TP68,TP93,TP94,TP95,TP112,TP113,TP114 ,TP115,TP116,TP117,TP118,TP131,TP147,T P148		TEST POINT PC MULTI PURPOSE RED TH	5010	KEYSTONE ELECTRONICS	

5 Installing and Configuring Software and Tools

Unzip the NXP_GUI_PR_4.1.0 into any desired location. Find the NXP_GUI-4.1.0-Setup from the GUI folder inside the package and run it to install the GUI in any desired location.

5.1 Freedom board BOOTLOADER refresh in a Windows 7 system

Note: This procedure does not apply if the board is already programmed.

1. Ensure that the boot loader in the GUI package is the latest specified in the link below. If not, download the latest boot loader for the specific MCU(K82F) from the location below:
<https://os.mbed.com/blog/entry/DAPLink-bootloader-update/>
2. Press the RST push button on the Freedom board and connect the USB cable to the SDA port (J5) on the Freedom board. A new "BOOTLOADER" device appears on the left pane of the File Explorer.

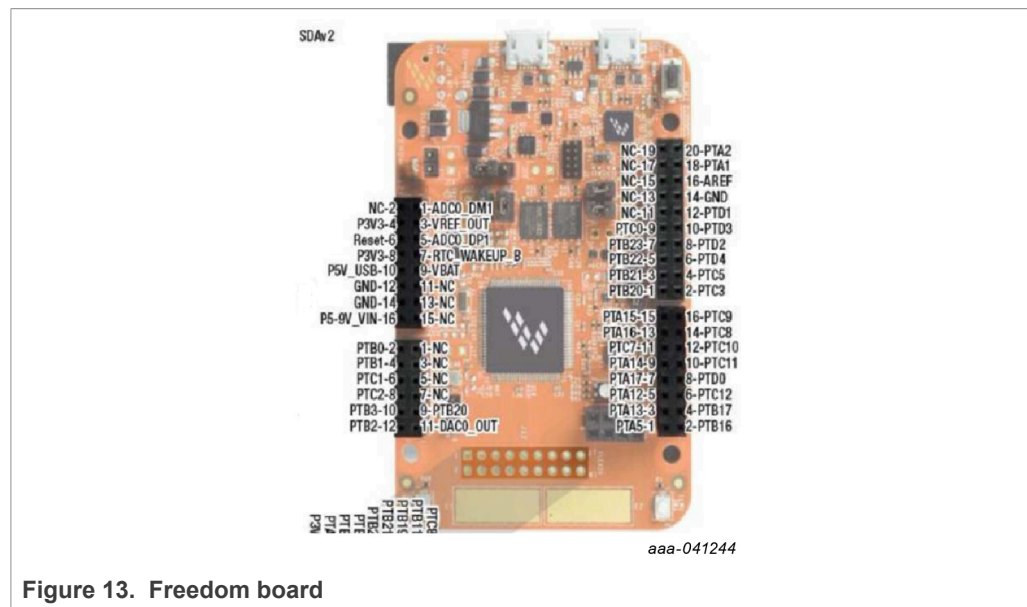

Figure 13. Freedom board

3. Drag and drop the downloaded file "0244_k20dx_bootloader_update_0x8000.bin" into the BOOTLOADER drive.
Note: Ensure that enough time is allowed for the firmware to be saved in the boot loader.
4. Disconnect and reconnect the USB cable into the SDA port (this time without pressing the RST push button).
5. Drag and drop the file "k20dx_frdmk82f_if_crc_legacy_0x8000.bin" from the package (MCU/K82F_FW folder) into the BOOTLOADER drive.
Note: Make sure to allow enough time for the firmware to be saved in the Bootloader. The device should change to FRDM_K82FD.
6. Locate the file "nxp-gui-fw-frdmk82f-usb_hid-vr5510_b0_v0.7.3.bin" from the package (MCU/K82F_FW folder) and drag and drop the file into the FRDM_K82FD device.
7. The Freedom board firmware is successfully loaded. Disconnect and reconnect the USB cable to the USB port. Open the previously installed NXPGUI. The "Start" button on the top left corner must be activated.

5.2 Freedom Board BOOTLOADER Refresh in a Windows 10 System

Note: This procedure does not apply if the board is already programmed.

1. If only the NXPGUI firmware has to be updated, start from Step 4 in [Section 5.1 "Freedom board BOOTLOADER refresh in a Windows 7 system"](#). The PC detects FRDM_K82FD. Proceed to Step 6 to load the latest firmware file received from NXP and follow up with Step 7.
2. If only the NXPGUI firmware has to be updated, start from Step 4 in [Section 5.1 "Freedom board BOOTLOADER refresh in a Windows 7 system"](#). The PC detects FRDM_K82FD. Proceed to Step 6 to load the latest firmware file received from NXP and follow up with step 7.
3. Download the latest bootloader from this location below for the specific MCU(K82F): <https://os.mbed.com/blog/entry/DAPLink-bootloader-update/>
4. Disable the storage services: Run services.msc, then double click on the storage service from the list and press the stop button.

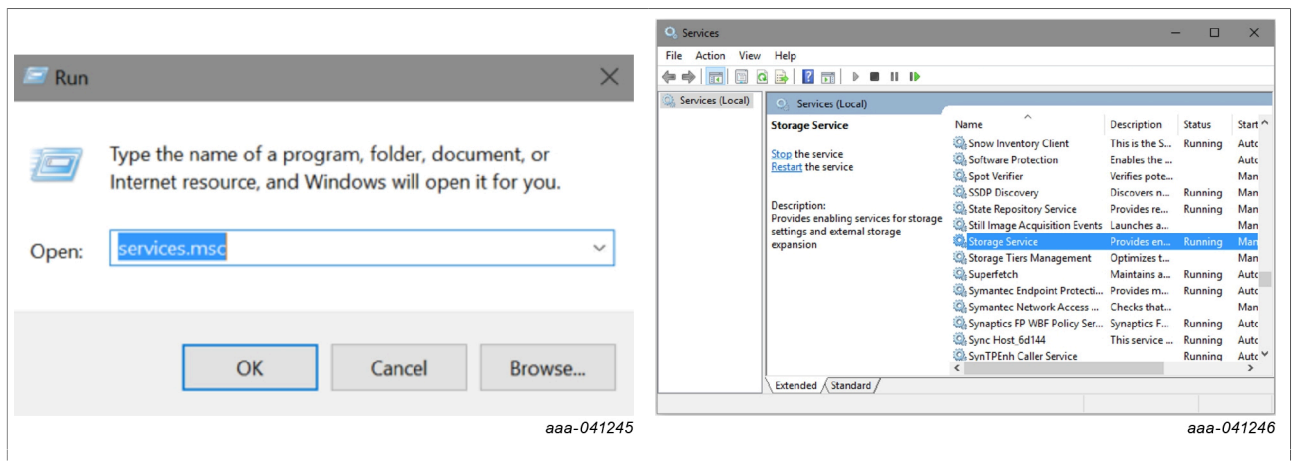

5. Press the RST push button on the Freedom board and connect the USB cable to the SDA port (J5) on the Freedom board. A new "BOOTLOADER" device appears on the left pane of the File explorer .
6. Drag and drop the downloaded boot loader file into the BOOTLOADER drive.
Note: Ensure that enough time is allowed for the firmware to be saved in the boot loader.
7. Disconnect and reconnect the USB cable to the SDA port (this time without pressing the RST push button). The drive is changed to "MAINTENANCE".
8. Follow Steps 5-7 from [Section 5.1 "Freedom board BOOTLOADER refresh in a Windows 7 system"](#).
9. If only firmware update is required, then repeat Step 1 above.
10. Reenable the services by following Step 2, but now pressing the start button.

5.3 Connecting to the KITVR5510SKTEVM board

1. With the USB cable connected to the PC and the USB port in the FRDM-K82F, apply power to the evaluation board:
 - Provide 12 V externally on J92 and J93 (VIN/VBAT, GND).
 - Ensure that the jumpers and switches are configured as explained in [Section 4.1.2.3 "Jumpers"](#). Configuring the jumpers and switches is only required if the board comes without a preconfigured jumper set.
2. To ensure that the board is properly recognized, press the Reset button on the Freedom board.
3. Run the installed NXPGUI application from the start menu or the installation folder.
4. A configuration window appears. Select the kit type and the device silicon version and click OK.

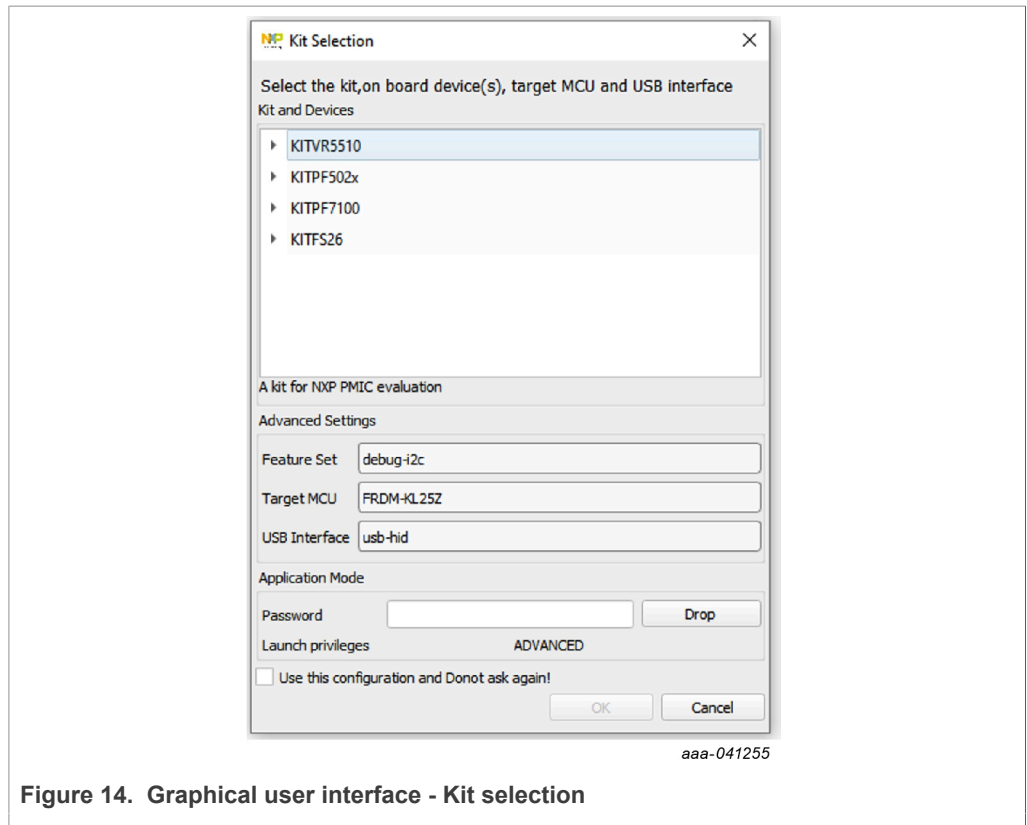
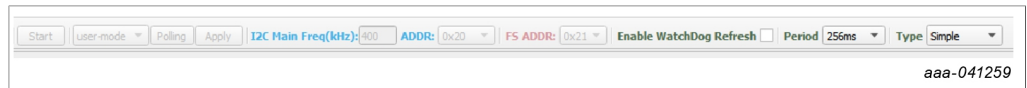

Figure 14. Graphical user interface - Kit selection

5. To enable the connection to the device, click the Start button. When the device is connected properly, the Start button is active and the system is ready for normal or debug operation.



6. If the NXPGUI does not recognize the FRDM-K82F board or if the Start button does not activate the device, it is possible that the interface is broken. In this case, re-programming of the FRDM-K82F board can be attempted by following steps in [Section 5.1 "Freedom board BOOTLOADER refresh in a Windows 7 system"](#).

5.4 Connecting to a reference board with K82F only

Most of the customer reference boards do not have the K82F board as part of the design. In those cases, a host system and a software/driver package must be available to interface with the VR5510 PMIC. If they are not available during the development phase, the following steps can be taken to operate the PMIC in different modes.

1. If the FRDM-K82F board must be programmed or if the firmware must be flashed again, follow the steps in [Section 5 "Installing and Configuring Software and Tools"](#).
2. The existing NXPGUI firmware provided with the software package (see [Section 5 "Installing and Configuring Software and Tools"](#)) can be used to establish the interface between an external FRDM-K82F board and customer reference board.
3. Follow the setup below or connection between a FRDM-K82F board and the reference board.
 - a. Connect the USB cable from a host to the USB port of the FRDM-K82F (J11)
 - b. Connect wires from the ports of the FRDM-K82F (PTC10 -SCL, PTC11-SDA, and GND) to the corresponding headers/pins on the reference board.
 - c. None of the other headers or pins on the FRDM-K82F board have to be connected.
 - d. Turn on the reference board by applying power and ensure that the VR5510 powers up with the default OTP settings. Follow the debug entry steps mentioned in [Section 6.1 "Operating in debug mode"](#).
 - e. Ensure that the reference board has the right pull-up voltage for the I2C_SCL and I2C_SDA lines applied through the correct resistor values (2.2 K Ω to VDDIO).
 - f. If VDDIO or any other pull-up source is not available, then the 3.3 V on the FRDM-K82F board can be used. In this case, additional wires/connection are required from pin 8 of J3 (P3V3) of the FRDM-K82F to the reference board through the appropriate resistors. A jumper should be used to isolate one connection when the other is used.
4. To initiate the NXPGUI and to start communicating with VR5510 on the reference board, follow the steps in [Section 5.3 "Connecting to the KITVR5510SKTEVM board"](#).

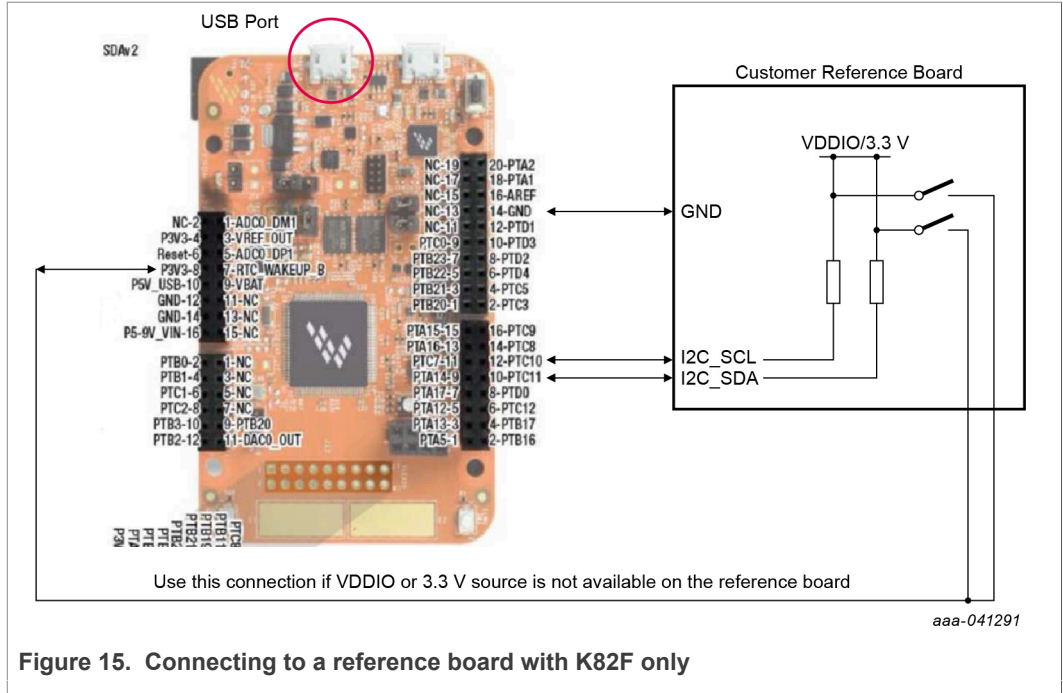

Figure 15. Connecting to a reference board with K82F only

6 Using the KITVR5510SKTEVM Evaluation Board

This section summarizes the overall setup. Detailed description is provided in the sections below.

6.1 Operating in debug mode

To operate the device in debug mode and verify the functionality, a debug/emulation script can be created using the OTP section of the NXPGUI tool.

1. To open the OTP configuration tool, click the OTP icon on the left side of the NXPGUI. The OTP tool can be used independently of the EV kit board status (the board does not have to be connected).
2. Configure the desired settings.
3. Generate a TBB script using the Export section of the menu bar.
4. Save the generated file in a known location as a .txt file.

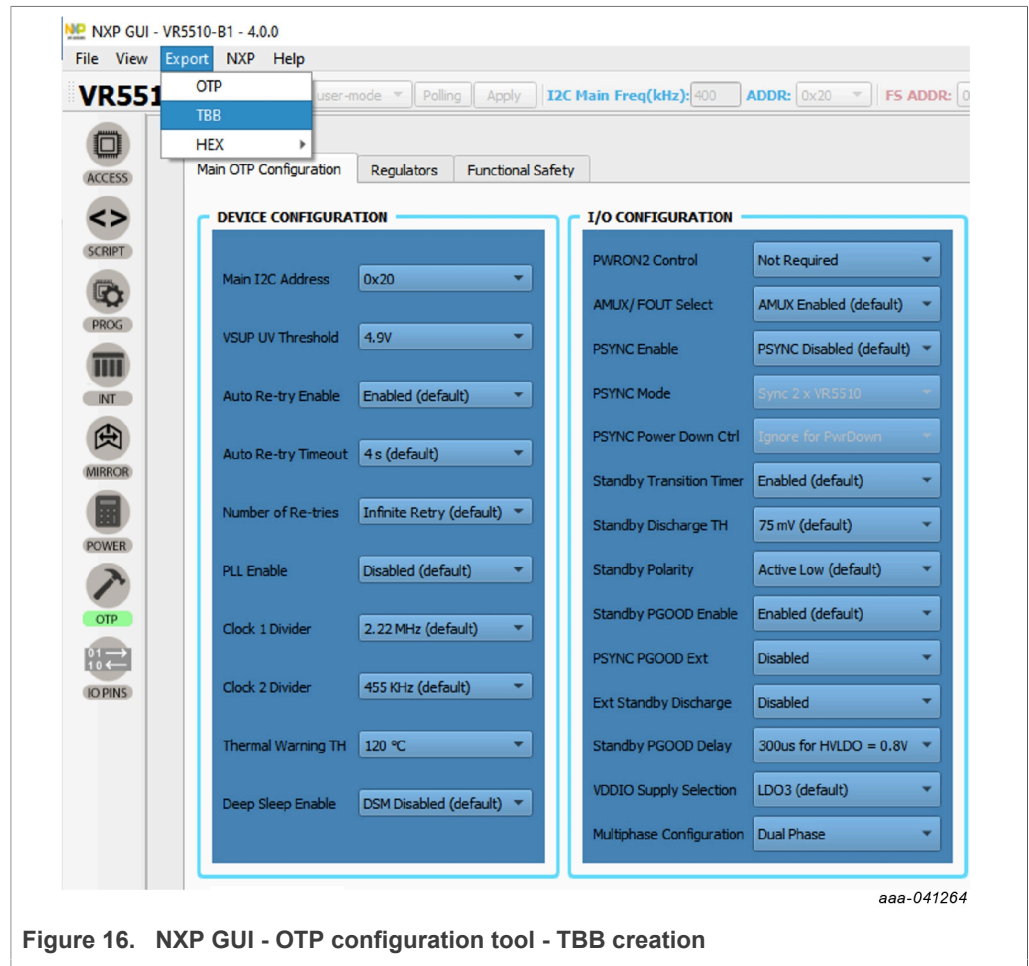
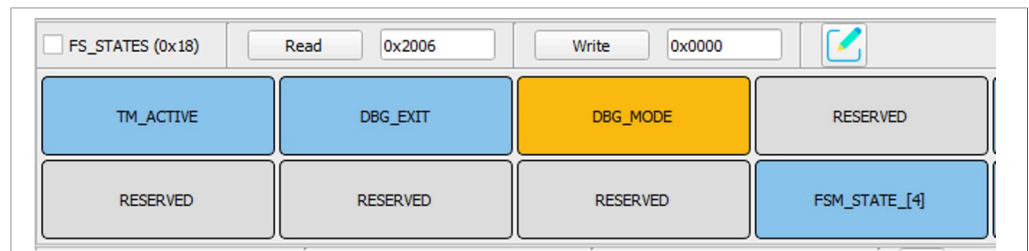

Figure 16. NXP GUI - OTP configuration tool - TBB creation

- 5. To operate the Board in debug mode:
 - Set SW2 to position to 1 (PWRON1 low);
 - Short J12 in position 2-3 and J11 in position 1-2 (to Apply > 5 V on the VDDOTP pin) using a jumper.Or:
 - To use the battery voltage directly for VDDOTP generation, short J12 in position 1-2. In this case, SW5 must be in position 2 (ON).
 - Set SW2 to ON position (enables the debug mode of operation). Turns on the part in debug mode.
- 6. When the PMIC is ON, verify the debug mode of operation by reading the FS_STATES [0x18] register from the safety section (0x21h).



aaa-041279

Figure 17. Reading FS_STATES [0x18] register from safety section (0x21h)

- 7. Select the test-mode option from the menu and click Apply.



aaa-041280

Figure 18. Selecting test-mode option

- Read M_TM_STATUS1[0x25] from the M_TestMode (main) section and FS_STATES[0x18] register from the safety section in the register map. In this way, the user can access the OTP mirror registers in debug mode.

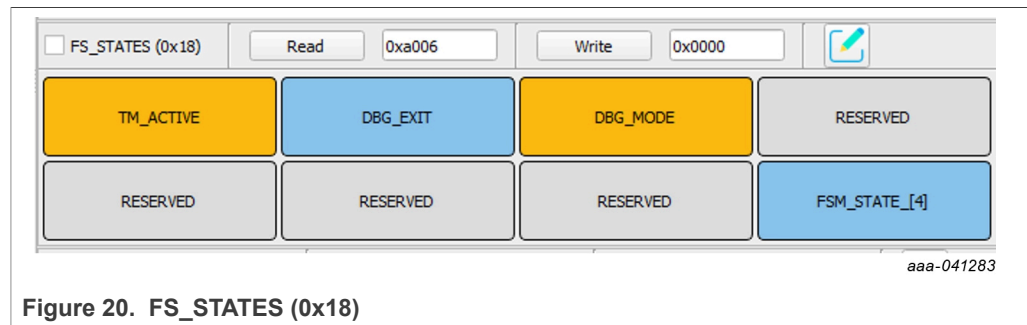
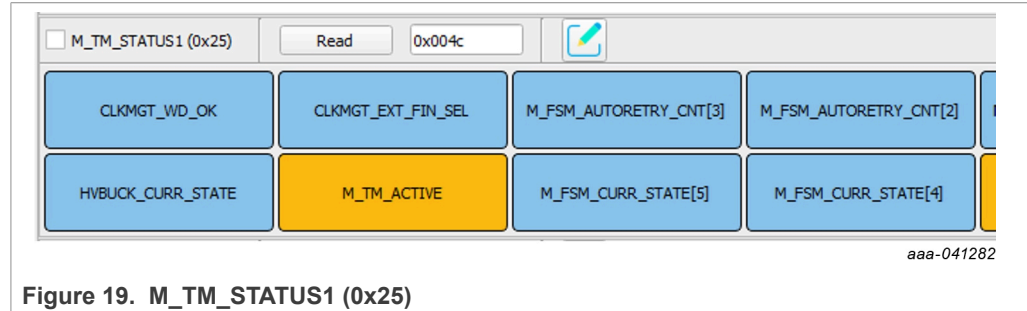

- On the Script section of the GUI, use the command section to load the debug script created. Then click Run.
- When programming the script is finished, remove the jumper from J11 or set SW5 low to bring the device out of debug and begin operation with the selected configuration.

6.2 Programming/burning OTP in debug mode

To program the OTP, the device must be operated in debug mode and test mode. To enter debug mode of operation and test mode, follow the steps mentioned in [Section 6.1 "Operating in debug mode"](#). An OTP script can be created using the OTP section of the tool as explained above in [Section 6.1 "Operating in debug mode"](#).

- Follow steps 1 to 4 of [Section 6.1 "Operating in debug mode"](#). Generate an OTP script using the Export section of the menu bar (make sure to fill all required fields marked with a * to enable the file generation Ready).
- Save the generated OTP file in a known location as a .txt file.
- To configure the board for test mode and debug mode operation, follow steps 5 to 8. Verify by reading back the registers to confirm test mode entry.
Note: to allow access to OTP mirror registers, test mode entry is essential for the device.
- Go to the PROG section in the NXPGUI tool. The PROG section is only activated when the test mode entry is successful.

5. Select the config source as “script” and locate the *.txt OTP file that was previously created using the OTP tool.

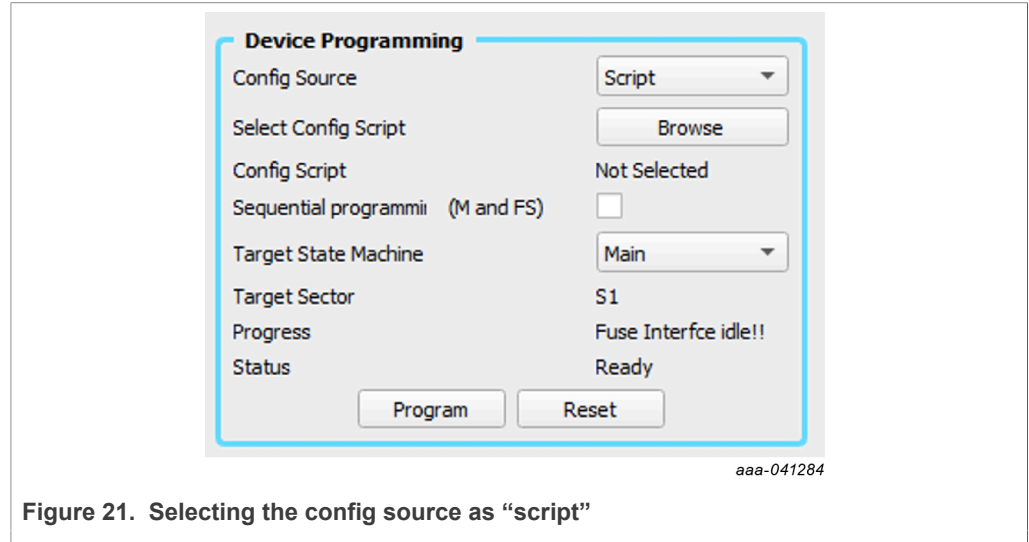

Figure 21. Selecting the config source as “script”

6. To program the main and fail-safe OTP fuses together or separately, check or uncheck the sequential programming option. If programming separately, then select the target state machine and click the program button. Follow the instructions.
7. If the OTP fuse burning was successful, the progress is updated and the fuse box status is automatically updated.

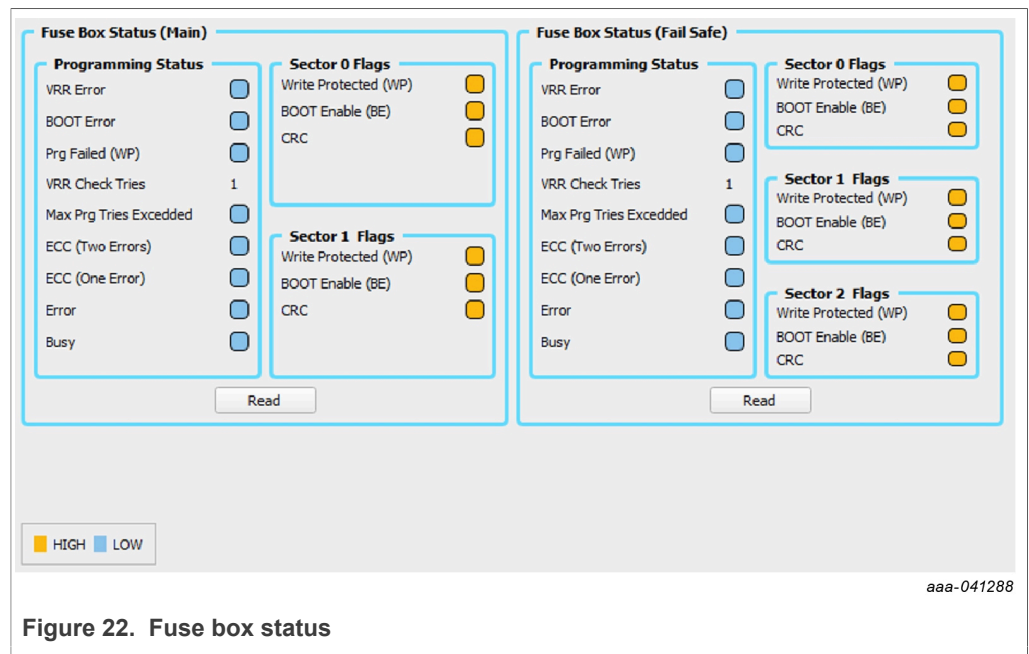

Figure 22. Fuse box status

8. Remove the jumper on J11 or set SW5 low to exit the debug mode. The part must turn on with the new OTP settings burnt with above steps. To verify successful OTP

burning, power cycle the board and check if the part turns on with the expected configuration.

7 References

Table 4. References

Document	Description	URL
KITVR5510SKTEVM Evaluation Kit	Product summary page	http://http://www.nxp.com/KITVR5510SKTEVM
FRDM-K82F Freedom Board for Kinetis K82F Hardware	Product summary page	http://www.nxp.com/frdm-k82f
FRDM-K82F User's Guide	User manual for FRDM-K82F Freedom Board for Kinetis K82F Hardware	https://www.nxp.com/docs/en/user-guide/FRDMK82FUG.pdf
VR5510 Data sheet	VR5510 Multi-Output PMIC with SMPS and LDO data sheet	https://www.nxp.com/docs/en/data-sheet/VR5510.pdf
VR5510 Safety Manual	VR5510 Multi-Output PMIC with SMPS and LDO Safety manual	Available at DocStore
VR5510 FMEDA	VR5510 FMEDA	Available at DocStore
AN13118	VR5510 S32G Safety Concept	https://nxp.com/doc/AN13118
AN12880	VR5510 Low Power Standby Mode	https://nxp.com/doc/AN12880
AN13182	VR5510 Device Design Guidelines	https://nxp.com/doc/AN13182

8 Legal information

8.1 Definitions

Draft — A draft status on a document indicates that the content is still under internal review and subject to formal approval, which may result in modifications or additions. NXP Semiconductors does not give any representations or warranties as to the accuracy or completeness of information included in a draft version of a document and shall have no liability for the consequences of use of such information.

8.2 Disclaimers

Limited warranty and liability — Information in this document is believed to be accurate and reliable. However, NXP Semiconductors does not give any representations or warranties, expressed or implied, as to the accuracy or completeness of such information and shall have no liability for the consequences of use of such information. NXP Semiconductors takes no responsibility for the content in this document if provided by an information source outside of NXP Semiconductors. In no event shall NXP Semiconductors be liable for any indirect, incidental, punitive, special or consequential damages (including - without limitation - lost profits, lost savings, business interruption, costs related to the removal or replacement of any products or rework charges) whether or not such damages are based on tort (including negligence), warranty, breach of contract or any other legal theory. Notwithstanding any damages that customer might incur for any reason whatsoever, NXP Semiconductors' aggregate and cumulative liability towards customer for the products described herein shall be limited in accordance with the Terms and conditions of commercial sale of NXP Semiconductors.

Right to make changes — NXP Semiconductors reserves the right to make changes to information published in this document, including without limitation specifications and product descriptions, at any time and without notice. This document supersedes and replaces all information supplied prior to the publication hereof.

Suitability for use — NXP Semiconductors products are not designed, authorized or warranted to be suitable for use in life support, life-critical or safety-critical systems or equipment, nor in applications where failure or malfunction of an NXP Semiconductors product can reasonably be expected to result in personal injury, death or severe property or environmental damage. NXP Semiconductors and its suppliers accept no liability for inclusion and/or use of NXP Semiconductors products in such equipment or applications and therefore such inclusion and/or use is at the customer's own risk.

Applications — Applications that are described herein for any of these products are for illustrative purposes only. NXP Semiconductors makes no representation or warranty that such applications will be suitable for the specified use without further testing or modification. Customers are responsible for the design and operation of their applications and products using NXP Semiconductors products, and NXP Semiconductors accepts no liability for any assistance with applications or customer product design. It is customer's sole responsibility to determine whether the NXP Semiconductors product is suitable and fit for the customer's applications and products planned, as well as for the planned application and use of customer's third party customer(s). Customers should provide appropriate design and operating safeguards to minimize the risks associated with their applications and products. NXP Semiconductors does not accept any liability related to any default, damage, costs or problem which is based on any weakness or default in the customer's applications or products, or the application or use by customer's third party customer(s). Customer is responsible for doing all necessary testing for the customer's applications and products using NXP Semiconductors products in order to avoid a default of the applications and the products or of the application or use by customer's third party customer(s). NXP does not accept any liability in this respect.

Limiting values — Stress above one or more limiting values (as defined in the Absolute Maximum Ratings System of IEC 60134) will cause permanent

damage to the device. Limiting values are stress ratings only and (proper) operation of the device at these or any other conditions above those given in the Recommended operating conditions section (if present) or the Characteristics sections of this document is not warranted. Constant or repeated exposure to limiting values will permanently and irreversibly affect the quality and reliability of the device.

Terms and conditions of commercial sale — NXP Semiconductors products are sold subject to the general terms and conditions of commercial sale, as published at <http://www.nxp.com/profile/terms>, unless otherwise agreed in a valid written individual agreement. In case an individual agreement is concluded only the terms and conditions of the respective agreement shall apply. NXP Semiconductors hereby expressly objects to applying the customer's general terms and conditions with regard to the purchase of NXP Semiconductors products by customer.

Export control — This document as well as the item(s) described herein may be subject to export control regulations. Export might require a prior authorization from competent authorities.

Evaluation products — This product is provided on an "as is" and "with all faults" basis for evaluation purposes only. NXP Semiconductors, its affiliates and their suppliers expressly disclaim all warranties, whether express, implied or statutory, including but not limited to the implied warranties of non-infringement, merchantability and fitness for a particular purpose. The entire risk as to the quality, or arising out of the use or performance, of this product remains with customer. In no event shall NXP Semiconductors, its affiliates or their suppliers be liable to customer for any special, indirect, consequential, punitive or incidental damages (including without limitation damages for loss of business, business interruption, loss of use, loss of data or information, and the like) arising out of the use of or inability to use the product, whether or not based on tort (including negligence), strict liability, breach of contract, breach of warranty or any other theory, even if advised of the possibility of such damages. Notwithstanding any damages that customer might incur for any reason whatsoever (including without limitation, all damages referenced above and all direct or general damages), the entire liability of NXP Semiconductors, its affiliates and their suppliers and customer's exclusive remedy for all of the foregoing shall be limited to actual damages incurred by customer based on reasonable reliance up to the greater of the amount actually paid by customer for the product or five dollars (US\$5.00). The foregoing limitations, exclusions and disclaimers shall apply to the maximum extent permitted by applicable law, even if any remedy fails of its essential purpose.

Translations — A non-English (translated) version of a document is for reference only. The English version shall prevail in case of any discrepancy between the translated and English versions.

Security — Customer understands that all NXP products may be subject to unidentified or documented vulnerabilities. Customer is responsible for the design and operation of its applications and products throughout their lifecycles to reduce the effect of these vulnerabilities on customer's applications and products. Customer's responsibility also extends to other open and/or proprietary technologies supported by NXP products for use in customer's applications. NXP accepts no liability for any vulnerability. Customer should regularly check security updates from NXP and follow up appropriately. Customer shall select products with security features that best meet rules, regulations, and standards of the intended application and make the ultimate design decisions regarding its products and is solely responsible for compliance with all legal, regulatory, and security related requirements concerning its products, regardless of any information or support that may be provided by NXP. NXP has a Product Security Incident Response Team (PSIRT) (reachable at PSIRT@nxp.com) that manages the investigation, reporting, and solution release to security vulnerabilities of NXP products.

8.3 Trademarks

Notice: All referenced brands, product names, service names and trademarks are the property of their respective owners.

NXP — wordmark and logo are trademarks of NXP B.V.

Tables

Tab. 1.	LEDs	7	Tab. 3.	Bill of Materials	15
Tab. 2.	Jumpers	9	Tab. 4.	References	29

Figures

Fig. 1.	LEDs, switches, and sockets	7	Fig. 14.	Graphical user interface - Kit selection	21
Fig. 2.	Connectors	8	Fig. 15.	Connecting to a reference board with K82F only	23
Fig. 3.	Jumpers	9	Fig. 16.	NXP GUI - OTP configuration tool - TBB creation	24
Fig. 4.	Test points	11	Fig. 17.	Reading FS_STATES [0x18] register from safety section (0x21h)	25
Fig. 5.	KITVR5510SKTEVM layout – top	12	Fig. 18.	Selecting test-mode option	25
Fig. 6.	KITVR5510SKTEVM layout – layer 2	12	Fig. 19.	M_TM_STATUS1 (0x25)	26
Fig. 7.	KITVR5510SKTEVM layout – layer 3	13	Fig. 20.	FS_STATES (0x18)	26
Fig. 8.	VR5510SKTEVM layout – layer 4	13	Fig. 21.	Selecting the config source as “script”	27
Fig. 9.	KITVR5510SKTEVM layout – layer 5	14	Fig. 22.	Fuse box status	27
Fig. 10.	KITVR5510SKTEVM layout – layer 6	14			
Fig. 11.	KITVR5510SKTEVM layout – layer 7	15			
Fig. 12.	KITVR5510SKTEVM layout – bottom	15			
Fig. 13.	Freedom board	19			

Contents

1 Introduction 3

2 Finding Kit Resources and Information on the NXP Web Site4

2.1 Collaborate in the NXP community4

3 Getting Ready5

3.1 Kit contents5

3.2 Additional hardware5

3.3 Windows PC workstation5

3.4 Software5

4 Getting to Know the Hardware 6

4.1 KITVR5510STKEVM overview 6

4.1.1 KITVR5510SKTEVM features6

4.1.2 Board descriptions6

4.1.2.1 LEDs, switches, and sockets7

4.1.2.2 Connectors8

4.1.2.3 Jumpers9

4.1.2.4 Test points 11

4.1.3 Layout 12

4.1.4 Bill of Materials 15

5 Installing and Configuring Software and Tools 19

5.1 Freedom board BOOTLOADER refresh in a Windows 7 system 19

5.2 Freedom Board BOOTLOADER Refresh in a Windows 10 System20

5.3 Connecting to the KITVR5510SKTEVM board21

5.4 Connecting to a reference board with K82F only 22

6 Using the KITVR5510SKTEVM Evaluation Board24

6.1 Operating in debug mode24

6.2 Programming/burning OTP in debug mode 26

7 References29

8 Legal information30

Please be aware that important notices concerning this document and the product(s) described herein, have been included in section 'Legal information'.

© NXP B.V. 2021.

All rights reserved.

For more information, please visit: <http://www.nxp.com>

For sales office addresses, please send an email to: salesaddresses@nxp.com

Date of release: 3 May 2021
 Document identifier: UM11586