

SOT1981-1

FM8, flange mount package, 8 terminals, 1.02 mm pitch, 10.26 mm x 10.26 mm x 3.81 mm body

8 November 2019

Package information

1 Package summary

Terminal position code	S (single)
Package type descriptive code	FM8
Mounting method type	F (flange mount)
Issue date	29-10-2019
Manufacturer package code	98ASA01217D

Table 1. Package summary

Parameter	Min	Nom	Max	Unit
package length	10.21	10.26	10.31	mm
package width	10.21	10.26	10.31	mm
seated height	3.73	3.81	3.89	mm
nominal pitch	-	1.02	-	mm
actual quantity of termination	-	8	-	



FM8, flange mount package, 8 terminals, 1.02 mm pitch, 10.26 mm x 10.26 mm x 3.81 mm body

2 Package outline

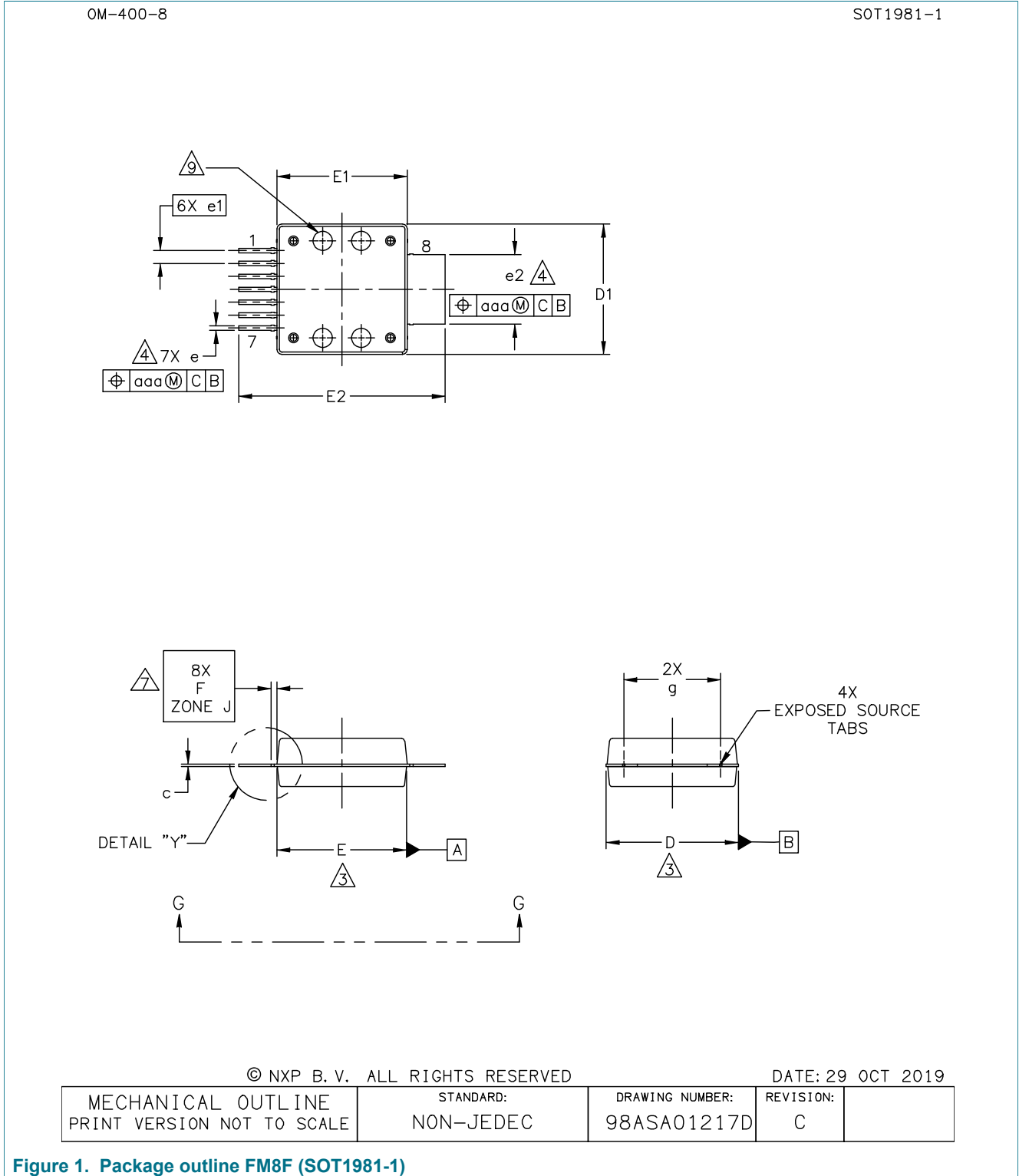

FM8, flange mount package, 8 terminals, 1.02 mm pitch, 10.26 mm x 10.26 mm x 3.81 mm body

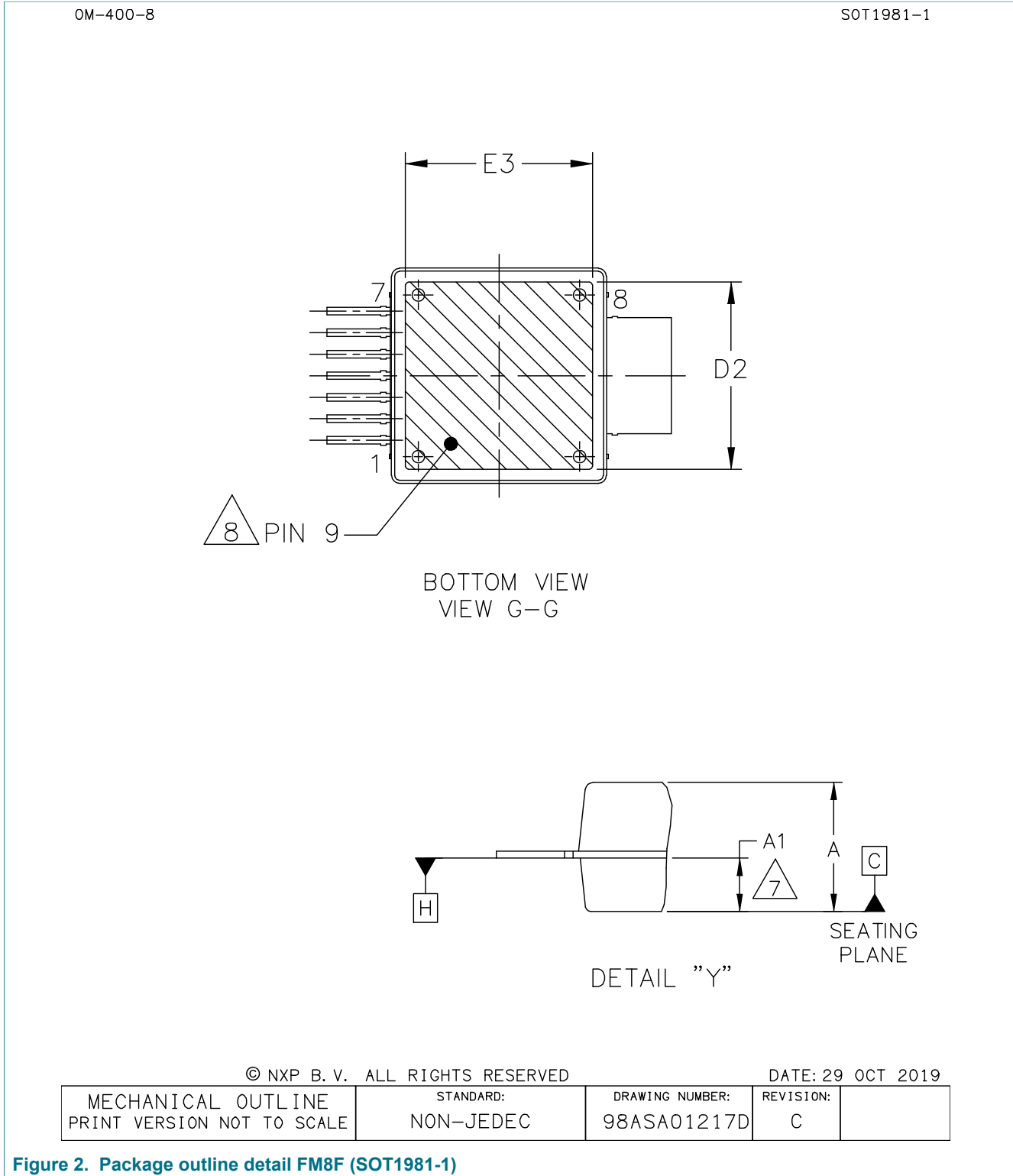

FM8, flange mount package, 8 terminals, 1.02 mm pitch, 10.26 mm x 10.26 mm x 3.81 mm body

OM-400-8

SOT1981-1

NOTES:

1. CONTROLLING DIMENSION: INCH
2. INTERPRET DIMENSIONS AND TOLERANCES PER ASME Y14.5M-1994.
3. DIMENSIONS D & E DOES NOT REFLECT PLASTIC OR METAL PROTRUSIONS OF PACKAGE PART LINE. ALLOWABLE PROTRUSION IS .006 INCH (0.15 MM).
4. DIMENSIONS e & e2, DO NOT INCLUDE DAMBAR PROTRUSIONS. ALLOWABLE PROTRUSIONS IS .005 INCH (0.13 MM).
5. DATUM PLANE H IS LOCATE AT THE BOTTOM OF THE LEAD AND IS COINCIDENT WITH THE LEAD WHERE THE LEAD EXITS THE PLASTIC BODY AT THE BOTTOM OF THE PARTING LINE.
6. DATUMS A AND B TO BE DETERMINED AT DATUM PLANE H.
7. DIMENSION A1 APPLIES WITHIN ZONE J ONLY.
8. HATCHING AREA REPRESENTS EXPOSED AREA OF THE HEATSINK. DIMENSIONS D1 AND E1 REPRESENT THE VALUES BETWEEN THE TWO OPPOSITE POINTS ALONG THE EDGES OF THE EXPOSED AREA OF HEAT SLUG.
9. DIMPLED HOLE REPRESENTS PIN 1.

DIM	INCH		MILLIMETER		DIM	INCH		MILLIMETER	
	MIN	MAX	MIN	MAX		MIN	MAX	MIN	MAX
A	.147	.153	3.73	3.89	e1	.040 BSC		1.02 BSC	
A1	.059	.065	1.50	1.65	e2	.213	.219	5.41	5.56
D	.398	.402	10.11	10.21	c	.007	.009	0.18	0.23
D1	.402	.406	10.21	10.31	g	.295	.305	7.49	7.75
D2	.343	.353	8.71	8.97	aaa	.005		0.13	
E	.398	.402	10.11	10.21					
E1	.402	.406	10.21	10.31					
E2	.636	.644	16.15	16.36					
E3	.343	.353	8.71	8.97					
F	.025 BSC		0.635 BSC						
e	.011	.017	0.28	0.43					

© NXP B. V. ALL RIGHTS RESERVED

DATE: 29 OCT 2019

MECHANICAL OUTLINE PRINT VERSION NOT TO SCALE	STANDARD: NON-JEDEC	DRAWING NUMBER: 98ASA01217D	REVISION: C	
--	------------------------	--------------------------------	----------------	--

Figure 3. Package outline note FM8F (SOT1981-1)

3 Legal information

Disclaimers

Limited warranty and liability — Information in this document is believed to be accurate and reliable. However, NXP Semiconductors does not give any representations or warranties, expressed or implied, as to the accuracy or completeness of such information and shall have no liability for the consequences of use of such information. NXP Semiconductors takes no responsibility for the content in this document if provided by an information source outside of NXP Semiconductors.

In no event shall NXP Semiconductors be liable for any indirect, incidental, punitive, special or consequential damages (including - without limitation - lost profits, lost savings, business interruption, costs related to the removal or replacement of any products or rework charges) whether or not such damages are based on tort (including negligence), warranty, breach of contract or any other legal theory.

Notwithstanding any damages that customer might incur for any reason whatsoever, NXP Semiconductors' aggregate and cumulative liability towards customer for the products described herein shall be limited in accordance with the Terms and conditions of commercial sale of NXP Semiconductors.

Right to make changes — NXP Semiconductors reserves the right to make changes to information published in this document, including without limitation specifications and product descriptions, at any time and without notice. This document supersedes and replaces all information supplied prior to the publication hereof.

Contents

1 Package summary1
2 Package outline2
3 Legal information5