

Mask Set Errata

MSE908JK3_2J88Y
12/2002

Mask Set Errata for 908JK3,
Mask 2J88Y



Introduction

This mask set errata applies to this 908JK3 MCU mask set:

- 2J88Y

MCU Device Mask Set Identification

The mask set is identified by a 5-character code consisting of a version number, a letter, two numerical digits, and a letter, for example 2J88Y. All standard devices are marked with a mask set number and a date code.

MCU Device Date Codes

Device markings indicate the week of manufacture and the mask set used. The date is coded as four numerical digits where the first two digits indicate the year and the last two digits indicate the work week. For instance, the date code "0201" indicates the first week of the year 2002.

MCU Device Part Number Prefixes

Some MCU samples and devices are marked with an SC, PC, or XC prefix. An SC prefix denotes special/custom device. A PC prefix indicates a prototype device which has undergone basic testing only. An XC prefix denotes that the device is tested but is not fully characterized or qualified over the full range of normal manufacturing process variations. After full characterization and qualification, devices will be marked with the MC or SC prefix.

Glitch on Timer Buffered PWM Output

SE30-PWM

In timer buffered PWM operation, when a timer overflow (TOF) event or an output compare (OC) event coincides with a write to either pair of the timer channel registers (TCHxH/L), the duty cycle at the PWM output glitches to 0% or 100% momentarily, then returns to proper operation.

To avoid the glitches when changing the PWM duty cycle, do not write to either pair of the timer channel registers at the TOF or OC.

For example, in the TOF interrupt service routine: If the OC occurs near the last TOF, write to the timer channel registers after the OC; if the OC occurs near the next TOF, write to the timer channel registers before the OC. A write to the channel register high byte (TCHxH) should immediately followed by a write to the low byte (TCHxL) to avoid TOF or OC occurring between the writes. Instruction cycle times must be included when making timing calculations.

The figure below shows a typical timer buffered PWM output waveform, indicating the TOF and OC events.

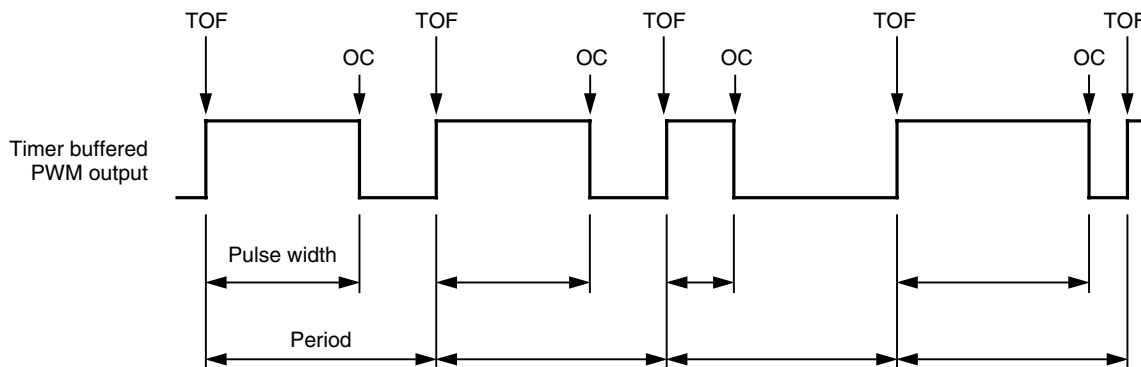

NOTES:

Do not write to either pair of timer channel registers at:
 TOF (timer overflow), or
 OC (timer output compare) edges.

In buffered PWM, the pulse width is defined by the last written pair of timer channel registers.
 Each pair of timer channel registers consist of a high byte register (TCHxH) and a low byte register (TCHxL).



HOW TO REACH US:**USA/EUROPE/LOCATIONS NOT LISTED:**

Motorola Literature Distribution;
P.O. Box 5405, Denver, Colorado 80217
1-303-675-2140 or 1-800-441-2447

JAPAN:

Motorola Japan Ltd.; SPS, Technical Information Center,
3-20-1, Minami-Azabu Minato-ku, Tokyo 106-8573 Japan
81-3-3440-3569

ASIA/PACIFIC:

Motorola Semiconductors H.K. Ltd.;
Silicon Harbour Centre, 2 Dai King Street,
Tai Po Industrial Estate, Tai Po, N.T., Hong Kong
852-26668334

TECHNICAL INFORMATION CENTER:

1-800-521-6274

HOME PAGE:

<http://www.motorola.com/semiconductors>

Information in this document is provided solely to enable system and software implementers to use Motorola products. There are no express or implied copyright licenses granted hereunder to design or fabricate any integrated circuits or integrated circuits based on the information in this document.

Motorola reserves the right to make changes without further notice to any products herein. Motorola makes no warranty, representation or guarantee regarding the suitability of its products for any particular purpose, nor does Motorola assume any liability arising out of the application or use of any product or circuit, and specifically disclaims any and all liability, including without limitation consequential or incidental damages. "Typical" parameters which may be provided in Motorola data sheets and/or specifications can and do vary in different applications and actual performance may vary over time. All operating parameters, including "Typicals" must be validated for each customer application by customer's technical experts. Motorola does not convey any license under its patent rights nor the rights of others. Motorola products are not designed, intended, or authorized for use as components in systems intended for surgical implant into the body, or other applications intended to support or sustain life, or for any other application in which the failure of the Motorola product could create a situation where personal injury or death may occur. Should Buyer purchase or use Motorola products for any such unintended or unauthorized application, Buyer shall indemnify and hold Motorola and its officers, employees, subsidiaries, affiliates, and distributors harmless against all claims, costs, damages, and expenses, and reasonable attorney fees arising out of, directly or indirectly, any claim of personal injury or death associated with such unintended or unauthorized use, even if such claim alleges that Motorola was negligent regarding the design or manufacture of the part.



Motorola and the Stylized M Logo are registered in the U.S. Patent and Trademark Office. digital dna is a trademark of Motorola, Inc. All other product or service names are the property of their respective owners. Motorola, Inc. is an Equal Opportunity/Affirmative Action Employer.

© Motorola, Inc. 2002