

A3M38SL039

Airfast Power Amplifier Module with Autobias Control

Rev. 1 — 1 July 2024

Product data sheet



1 General description

The A3M38SL039 is a fully integrated Doherty power amplifier module designed for wireless infrastructure applications that demand high performance in the smallest footprint. Ideal for applications in massive MIMO systems, outdoor small cells and low power remote radio heads. The field-proven LDMOS power amplifiers are designed for TDD LTE and 5G systems. The module integrates an autobias feature with the option to overwrite production settings. Autobias automatically sets and regulates transistor bias over temperature upon power up. An integrated sensor for monitoring temperature is also present. Communications to the module can be accomplished via I²C.

2 Typical performance

Table 1. 3600–4000 MHz — Typical LTE performance

P_{out} = 8 W Avg., V_{DD} = 30 Vdc, 1 × 20 MHz LTE, Input Signal PAR = 8 dB @ 0.01% Probability on CCDF. [1]

Carrier Center Frequency	Gain (dB)	ACPR (dBc)	PAE (%)
3610 MHz	28.2	-29.1	32.7
3800 MHz	28.2	-28.9	34.1
3990 MHz	28.1	-27.2	31.8

[1] All data measured with device soldered in NXP reference circuit.

3 Features and benefits

- Advanced high performance in-package Doherty
- Fully matched (50 ohm input/output, DC blocked)
- Designed for low complexity digital linearization systems
- Autobias on power up
- Temperature sensing
- I²C digital interface
- Embedded registers and DACs for setting bias conditions
- Tx Enable control pin for TDD operation

4.2 Functional pin description

Table 2. Functional pin description

Pin Number	Pin Function	Pin Description
1	V _{DC2}	Carrier Drain Supply, Stage 2
2	V _{DC1}	Carrier Drain Supply, Stage 1
3, 5, 6, 8, 14, 17, 22, 23, 25, 26, 27, 28, 29, 30, 31, 32, 33, 34, 35, 36, 37, 38	GND	Ground
4, 18, 21	N.C.	No Connection
7	RF _{in}	RF Input Signal @ 50 Ohm
9	A1	I ² C Address A1 (tri-state, tie to 5 V, tie to ground or leave floating)
10	A0	I ² C Address A0 (tri-state, tie to 5 V, tie to ground or leave floating)
11	SCLK	I ² C Serial Clock Signal (1.8 V JEDEC compatible)
12	SDA	I ² C Serial Data Signal (1.8 V JEDEC compatible)
13	CS_B	Inactive (recommend connection to 1.8 V supply)
15	Tx_EN	PA Enable Signal (1.8 V JEDEC compatible)
16	V _{CC_+5V}	5 V V _{CC} Power Source for Autobias Chip
19	V _{DP1}	Peaking Drain Supply, Stage 1
20	V _{DP2}	Peaking Drain Supply, Stage 2
24	RF _{out}	RF Output Signal @ 50 Ohm

5 Electrical characteristics

5.1 Ratings

5.1.1 Limiting values

Table 3. Limiting values

Rating	Symbol	Value	Unit
Operating Voltage Range	V_{CC_+5V}	4.75 to 5.25	Vdc
5 V_{CC} Slew Rate, $T_C = 25^\circ\text{C}$	$V_{CC_+5V_SLEW}$	9.5	ms
Operating Voltage Range	V_{DD}	24 to 30	Vdc
Operating Voltage Range	A1, A0	4.75 to 5.25	Vdc
Operating Voltage Range	SDA, SCLK, Tx_EN	1.65 to 1.95	Vdc
Storage Temperature Range	T_{stg}	-65 to +150	$^\circ\text{C}$
Case Operating Temperature	T_C	125	$^\circ\text{C}$
Peak Input Power (3800 MHz, Pulsed CW, 10 $\mu\text{sec}(\text{on})$, 10% Duty Cycle)	P_{in}	25	dBm

5.1.2 Lifetime

Table 4. Lifetime

Characteristic	Symbol	Value	Unit
Mean Time to Failure (Case Temperature 125°C , Internal Sense Temperature 108°C , 8 W Avg., 75% Duty Cycle, 30 Vdc)	MTTF	>10	Years

5.1.3 ESD protection characteristics

Table 5. ESD protection characteristics

Test Methodology	Class
Human Body Model (per JS-001-2017)	3A
Charge Device Model (per JS-002-2014)	C3

5.1.4 Moisture sensitivity level

Table 6. Moisture sensitivity level

Test Methodology	Rating	Package Peak Temperature	Unit
Per JESD22-A113, IPC/JEDEC J-STD-020	3	260	$^\circ\text{C}$

5.2 Operating characteristics

5.2.1 Nominal DAC settings

Table 7. Nominal DAC settings^[1]

Characteristic	Symbol	Typ	Unit
Gate Quiescent DAC ($V_{DS} = 30$ Vdc, A_SENSE_DAC = 40, A_VGS1_DAC = 6)	I_{DQ1C}	26	mA
Gate Quiescent DAC ($V_{DS} = 30$ Vdc, A_SENSE_DAC = 40, A_VGS2_DAC = 34)	I_{DQ2C}	72	mA
Gate Quiescent DAC ($V_{DS} = 30$ Vdc, B_SENSE_DAC = 34, B_VGS1_DAC = 60)	I_{DQ1P}	1	mA
Gate Quiescent DAC ($V_{DS} = 30$ Vdc, B_SENSE_DAC = 34, B_VGS2_DAC = 80)	I_{DQ2P}	1	mA

[1] Each side of device measured separately.

5.2.2 Functional tests

Table 8. Functional tests — 3600 MHz

(In NXP Doherty Production ATE^[1] Test Fixture, 50 ohm system)^[2] $V_{DD} = 30$ Vdc, Nominal DAC Settings, $T_{X_EN} = High$, $P_{out} = 8$ W Avg., 1-tone CW, $f = 3600$ MHz.

Characteristic	Symbol	Min	Typ	Max	Unit
Gain	G	24.6	26.8	—	dB
Drain Efficiency	η_D	28.0	33.0	—	%
P_{out} @ 3 dB Compression Point (Pulsed CW, 5% Duty Cycle)	P3dB	45.7	46.9	—	dBm

[1] ATE is a socketed test environment.

[2] Part input and output matched to 50 ohms.

Table 9. Functional tests — 4000 MHz

(In NXP Doherty Production ATE^[1] Test Fixture, 50 ohm system)^[2] $V_{DD} = 30$ Vdc, Nominal DAC Settings, $T_{X_EN} = High$, $P_{out} = 8$ W Avg., 1-tone CW, $f = 4000$ MHz.

Characteristic	Symbol	Min	Typ	Max	Unit
Gain	G	25.5	27.6	—	dB
Drain Efficiency	η_D	27.0	32.8	—	%
P_{out} @ 3 dB Compression Point (Pulsed CW, 5% Duty Cycle)	P3dB	45.5	46.8	—	dBm

[1] ATE is a socketed test environment.

[2] Part input and output matched to 50 ohms.

5.2.3 Wideband ruggedness

Table 10. Wideband ruggedness

(In NXP Doherty Power Amplifier Module Reference Circuit, 50 ohm system)^[1] Nominal DAC Settings, Tx_EN = High, f = 3800 MHz, Additive White Gaussian Noise (AWGN) with 10 dB PAR.

Characteristic	Symbol	Min	Typ	Max	Unit
ISBW of 400 MHz at 30 Vdc, 3 dB Input Overdrive from 8 W Avg. Modulated Output Power	No Device Degradation				

[1] All data measured in fixture with device soldered in NXP reference circuit.

5.2.4 Typical performance

Table 11. Typical performance

(In NXP Doherty Power Amplifier Module Reference Circuit, 50 ohm system)^[1] V_{DD} = 30 Vdc, Nominal DAC Settings, Tx_EN = High, P_{out} = 8 W Avg., 3800 MHz.

Characteristic	Symbol	Min	Typ	Max	Unit
VBW Resonance Point, 2-tone, 1 MHz Tone Spacing (IMD Third Order Intermodulation Inflection Point)	VBW _{res}	—	400	—	MHz
1-carrier 20 MHz LTE, 8 dB Input Signal PAR					
Gain	G	—	28.2	—	dB
Power Added Efficiency	PAE	—	34.1	—	%
Adjacent Channel Power Ratio	ACPR	—	-28.9	—	dBc
Adjacent Channel Power Ratio	ALT1	—	-42.1	—	dBc
Adjacent Channel Power Ratio	ALT2	—	-52.4	—	dBc
Gain Flatness ^[2]	G _F	—	0.1	—	dB
Fast CW, 27 ms Sweep					
P _{out} @ 3 dB Compression Point	P3dB	—	47.8	—	dBm
AM/PM @ P3dB	Φ	—	-13	—	°
Gain Variation @ Avg. Power over Temperature (-40°C to +105°C)	ΔG	—	0.023	—	dB/°C
P3dB Variation over Temperature (-40°C to +105°C)	P3dB	—	0.008	—	dB/°C

[1] All data measured in fixture with device soldered in NXP reference circuit.

[2] Gain flatness = Max(G(f_{Low} to f_{High})) – Min(G(f_{Low} to f_{High})).

6 Register map and OTP memory

6.1 One-time programmable memory

The A3M38SL039 contains a one-time programmable (OTP) memory array that is used to store register values for the integrated autobias controller. The data sheet I_{DQ} target values are determined and programmed into the OTP memory during NXP's production testing. When programmed, the OTP memory is used to store these values for automatic loading into autobias registers at power on or reset. These values can be overwritten using the Engineering Mode (EM) sequence; however, the overwritten values do not persist after a power cycle or a reset.

The OTP memory can be programmed only by NXP during the manufacturing process and cannot be changed by the user. The values in OTP memory have been selected to allow the device to operate in a wide variety of applications.

6.2 Register map

There are nine 8-bit user accessible registers available in the A3M38SL039. The register mapping is listed in [Table 12](#). Address 0 RW register is designed to control soft reset, refresh OTP and read the chip version. Address 1–6 registers are RW and/or OTP controlled and provide settings for the two RF transistor group DACs. Address 15 is read only for temperature sense functionality. Address 17 is a virtual write only register for enabling Engineering Mode.

Table 12. Register map

Address (in Decimal)	Register Attribute	Register Name	Register Definition								Default Value
			bit7	bit6	bit5	bit4	bit3	bit2	bit1	bit0	
0	RW	System_Reg	N/A	Soft Reset	Refresh OTP	N/A	Chip Version [3:0] (Read only)			8'b0000_0001	
1	OTP COPY (RW)	A_Sense_DAC	Reserved		Group A Sense DAC					OTP value	
2	OTP COPY (RW)	A_VGS1_DAC	Group A V _{GS1} DAC								OTP value
3	OTP COPY (RW)	A_VGS2_DAC	Group A V _{GS2} DAC								OTP value
4	OTP COPY (RW)	B_Sense_DAC	Reserved		Group B Sense DAC					OTP value	
5	OTP COPY (RW)	B_VGS3_DAC	Group B V _{GS3} DAC								OTP value
6	OTP COPY (RW)	B_VGS4_DAC	Group B V _{GS4} DAC								OTP value
7–14	—	—	Reserved								—
15	RO	Temp_ADC	Temperature Sensor [7:0]								—
16	—	—	Reserved								—
17	Virtual W only	EM_Passcode	Engineering Mode (EM) passcode 8'hE3								—

- Read Only register (RO)
- Read Write register (RW)
- Read Write register with OTP overwrite at Startup (RW)
- Reserved non-accessible register
- Write Only register

Table 13. Register overview and bit description

Address	Register Name	Bit	Bit Descriptions	Power On/Reset Value ^[1]	Overwritten by OTP	Attribute	EM Mode
0	System_Reg	7	Not available	N/A	N/A	N/A	N/A
		6	Soft Reset. A 1 written to this register will perform a reset of all registers to their default values. A 0 should be written after the reset operation is completed.	0	No	RW	
		5	Refresh OTP. A 1 written to this register will overwrite values stored in OTP into registers identified in the "Overwritten by OTP" column. A 0 should be written after the reset operation is completed.	0	No		
		4	Not available	N/A	N/A	N/A	
		0–3	Chip version bits. Inserted by NXP to provide revision information. Cannot be changed.	N/A	No	R	
1	A_Sense_DAC	6–7	Not available	N/A	N/A	N/A	Yes
		0–5	Sense DAC A 6-bit logic value for carrier amplifiers. DAC A sets the reference voltage to compare to the V_{DS} across the reference device. Minimum typical value is 6'b001000 and maximum value is 6'b111111. Recommendation is that the value in this register be set higher than 6'b010000.	6'h20	Yes	RW ^[2]	
2	A_VGS1_DAC	0–7	Sets 8-bit DAC logic value for carrier amplifier driver stage. 8'h00 sets gate to equal ceiling voltage. 8'hFF reduces gate voltage by a max value.	8'h80			
3	A_VGS2_DAC	0–7	Sets 8-bit DAC logic value for carrier amplifier final stage. 8'h00 sets gate to equal ceiling voltage. 8'hFF reduces gate voltage by a max value.	8'h80			

(continued)

Table 13. Register overview and bit description (continued)

Address	Register Name	Bit	Bit Descriptions	Power On/Reset Value ^[1]	Overwritten by OTP	Attribute	EM Mode
4	B_Sense_DAC	6–7	Not available	N/A	N/A	N/A	No
		0–5	Sense DAC B 6-bit logic value for peaking amplifiers. DAC B sets the reference voltage to compare to the V_{DS} across the reference device. Minimum typical value is 6'b001000 and maximum value is 6'b111111. Recommendation is that the value in this register be set higher than 6'b010000.	6'h20	Yes	RW ^[2]	Yes
5	B_VGS3_DAC	0–7	Sets 8-bit DAC logic value for peaking driver stage. 8'h00 sets gate to equal ceiling voltage. 8'hFF reduces gate voltage by a max value.	8'h80			
6	B_VGS4_DAC	0–7	Sets 8-bit DAC logic value for peaking final stage. 8'h00 sets gate to equal ceiling voltage. 8'hFF reduces gate voltage by a max value.	8'h80			
7–14	Reserved	N/A	Not available	N/A	N/A	N/A	No
15	Temp_ADC	0–7	Temperature sensor 8-bit DAC value. 8'h00 is lowest temperature, 8'hFF is highest temperature.	8'h00	No	R	No
16	Reserved	N/A	Not available	N/A	N/A	N/A	No
17	EM_Passcode	0–7	Engineering Mode (EM). By writing 8'hE3 to this register the user can enter engineering mode. EM can be cleared by writing any other code to this register. In EM registers identified in EM mode column can be changed.	N/A	No	W	Yes

[1] At power on or reset, OTP values set by NXP are automatically loaded into registers indicated with a “Yes” in the “Overwritten by OTP” column. For these registers, values shown in the “Power On/Reset Value column” will be loaded only if OTP has not been programmed to prevent damage to the device.

[2] Register can be read at any time. Can write to register only when in Engineering Mode (EM).

7 Power supply sequence

Power Up Sequence

1. V_{CC_+5V} : 5 V power up
2. I²C interface is active
3. $V_{DP1}, V_{DP2}, V_{DC1}, V_{DC2}$ power up

Power Down Sequence

1. $V_{DP1}, V_{DP2}, V_{DC1}, V_{DC2}$ power down
2. I²C interface deactivated
3. V_{CC_+5V} : 5 V power down

Note: All digital interfaces (SDA, SCLK, CS_B, Tx_EN) are 1.8 V logic.

8 Autobias functionality

8.1 General overview

After power up, the integrated bias controller develops and applies a thermally compensated quiescent bias voltage to the gate of each of the four RF transistors contained within the power amplifier module (PAM) based on the preset OTP values. See [Section 6.1](#) for more information on the OTP memory. This achieves optimal RF performance over the full temperature range. The standard I²C interface can be used to read the temperature sensor and overwrite preset DAC values. The device can be used without the programming interface. The thermal compensation circuit is analog and not programmable; however, the preset DAC values can be overwritten to provide an alternate thermal compensation scheme via the I²C interface. This section describes the operation and programming of the bias controller.

8.2 Operational overview

[Figure 2](#) shows a detailed view of the carrier side (Group A) autobias controller. The peaking side (Group B) controller is a duplicate of the carrier; however, the RF transistor peripheries and quiescent operating points will be different as required by the Doherty operation. The module contains four RF LDMOS field-effect transistors (FET) consisting of a driver and final for the carrier amplifier (on a single IC die) and a driver and final for the peaking amplifier (on a single IC die). Each IC die also contains a small periphery reference FET that is designed to match the properties of the larger RF transistors with regard to part-to-part process and temperature-dependent variations. The bias controller interfaces with each of the RF FETs and provides flexibility to control the biasing of each transistor independently.

The bias controller operates by establishing a known current through the reference FET typically in the range of 1–2 mA per reference FET. This in turn establishes a gate-source operating voltage by sensing the voltage drop across an integrated, high tolerance resistor placed between V_{CC} (5 V) and the reference device drain terminal. The bias controller V_{CC_+5V} pin should be operated from a 5 V supply with tolerance of $\pm 5\%$. The reference voltage across the precision resistor R1 is compared to a voltage programmed in the bias controller (A_Sense_DAC and B_Sense_DAC), thereby providing fine incremental adjustment to the default bias current of the reference FET. Because the reference FET and RF FET are manufactured on the same die in close proximity, they exhibit similar process and temperature dependencies.

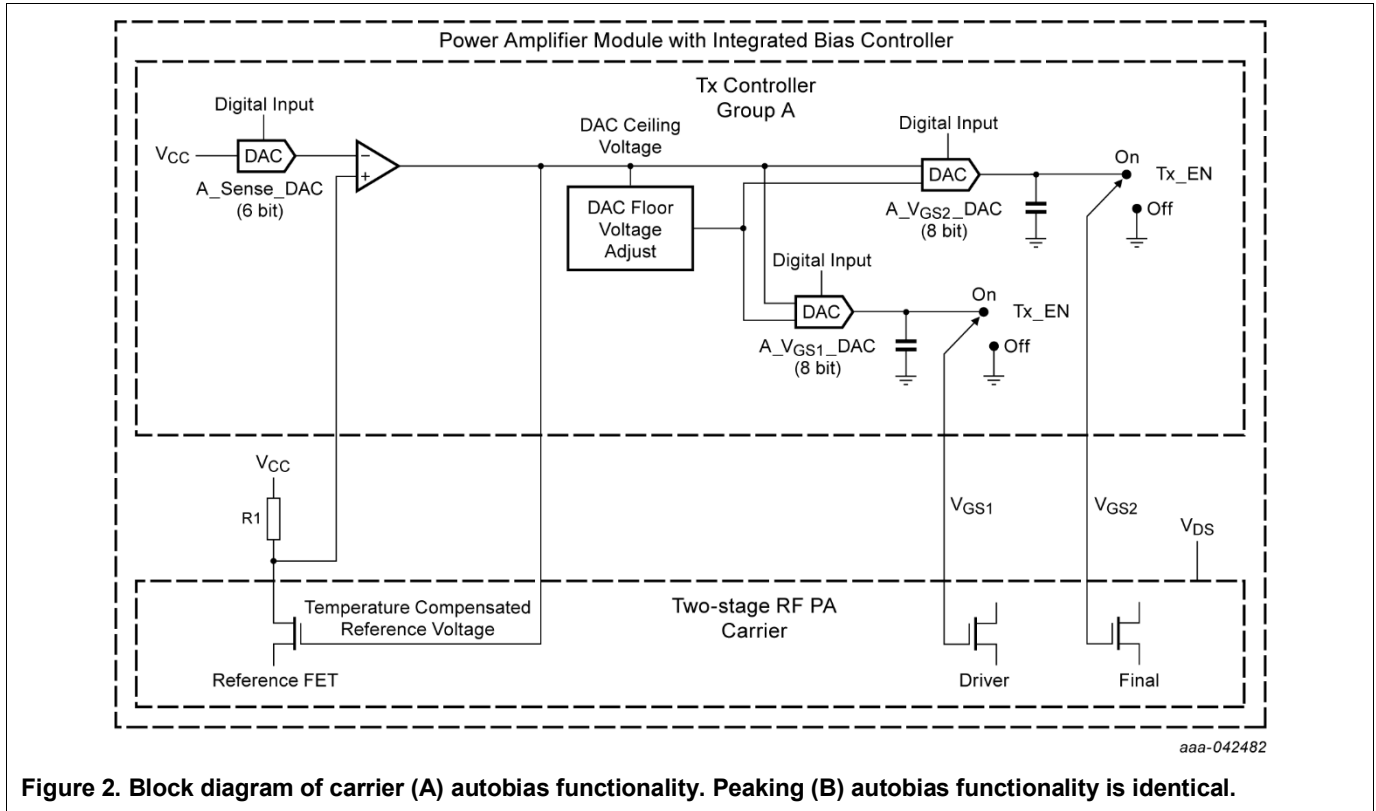

Figure 2. Block diagram of carrier (A) autobias functionality. Peaking (B) autobias functionality is identical.

The initial bias condition is set via the A_Sense_DAC register. The bias condition is then sensed and adjusted as temperature changes via the closed-loop feedback. The feedback mechanism adjusts the DAC ceiling voltage to maintain a constant I_{DS} current through the reference FET. The temperature compensated DAC ceiling voltage can either be passed to the carrier PA final and carrier PA driver directly, or reduced by values set in the A_VGS1_DAC and A_VGS2_DAC to the DAC floor voltage.

8.3 Tx enable control

A 1.8 V JEDEC compliant enable signal (Tx_EN) is included for bias On/Off operation to support TDD operation. The controller provides capability to quickly switch the RF FETs between ON and OFF modes in less than 100 ns. With Tx_EN in an ON state, the RF FET gate terminals are internally decoupled with sufficient capacitance providing a low impedance for wide baseband signals. The large capacitance also serves as a charge holding cap for reducing switching transient time in TDD operation. In Tx OFF mode, RF FET device gates are grounded shutting them OFF.

Table 14. TX_EN off-state typical currents

Characteristic	Typical Value	Unit
V _{CC} +5V Supply Current	11	mA
Combined Drain Supply Currents (V _{DC1} , V _{DC2} , V _{DP1} , V _{DP2})	20	μA

8.4 Sense_DAC

The current in the reference FET is controlled and programmed with 6 bits (two MSBs of the 8-bit register are not used) via the sense DAC (A_Sense_DAC and B_Sense_DAC). By programming the sense DAC, the RF stage DAC ceiling voltage reference operating point can be optimally set. The DAC ceiling voltage reference point impacts both RF PA stages (driver and final) simultaneously. After OTP has been programmed, the Sense_DAC is loaded with the programmed values and are then only programmable in Engineering Mode.

The factory programmed values for A_Sense_DAC and B_Sense_DAC are decimal 40 and 34 respectively. These values have been optimized for best power, linearity and efficiency tradeoffs.

8.5 VGS_DAC

The VGS_DAC voltage is determined via the Sense_DAC setting, creating the top end or ceiling of the VGS_DAC voltage range and a fixed offset voltage creating the bottom end or floor of the VGS_DAC voltage range. With a decimal VGS_DAC setting of 0, the gate voltage developed on the reference FET is buffered with minimum offset to the gates of the RF transistors in the carrier amplifier. As the VGS_DAC value increases, the voltage applied to the gates of the RF transistors decreases, which also reduces I_{DQ} . This allows the operating point of the four RF devices to be set to any desired value, from Class AB to Class C.

The reference FETs and RF FETs exhibit approximately the same current density (that is, I_{DQ}/mm gate width). It is important to note that, because the reference device and RF transistors are manufactured on the same die in close proximity, they exhibit similar process and temperature dependencies. Both the peaking amplifier and the carrier amplifier operate in the same way with regard to the reference device and the RF transistors.

8.6 Engineering Mode (EM)

Flexibility exists to overwrite the OTP memory values, if needed. A special Engineering Mode (EM) is available to allow the user to overwrite data that has been placed into the OTP memory space. To enter EM, issue the write address d'17 command with the predefined EM passcode (see [Table 12](#)). After entering EM, all DAC OTP registers (address 1–6) can be overwritten with the normal I²C write instruction. This interface programmed value will be valid so long the V_{CC} supply power is maintained. The V_{CC} power cycle will load OTP programmed DAC settings again. If the user writes the address d'17 register with any value other than the passcode, EM will automatically exit.

9 Ordering information

Table 15. Ordering information

Device	Tape and Reel Information	Digital Interface	Package
A3M38SL039IAAT2	T2 Suffix = 2,000 Units, 24 mm Tape Width, 13-inch Reel	I ² C	10 mm × 8 mm Module

10 Component layout and parts list

10.1 Component layout

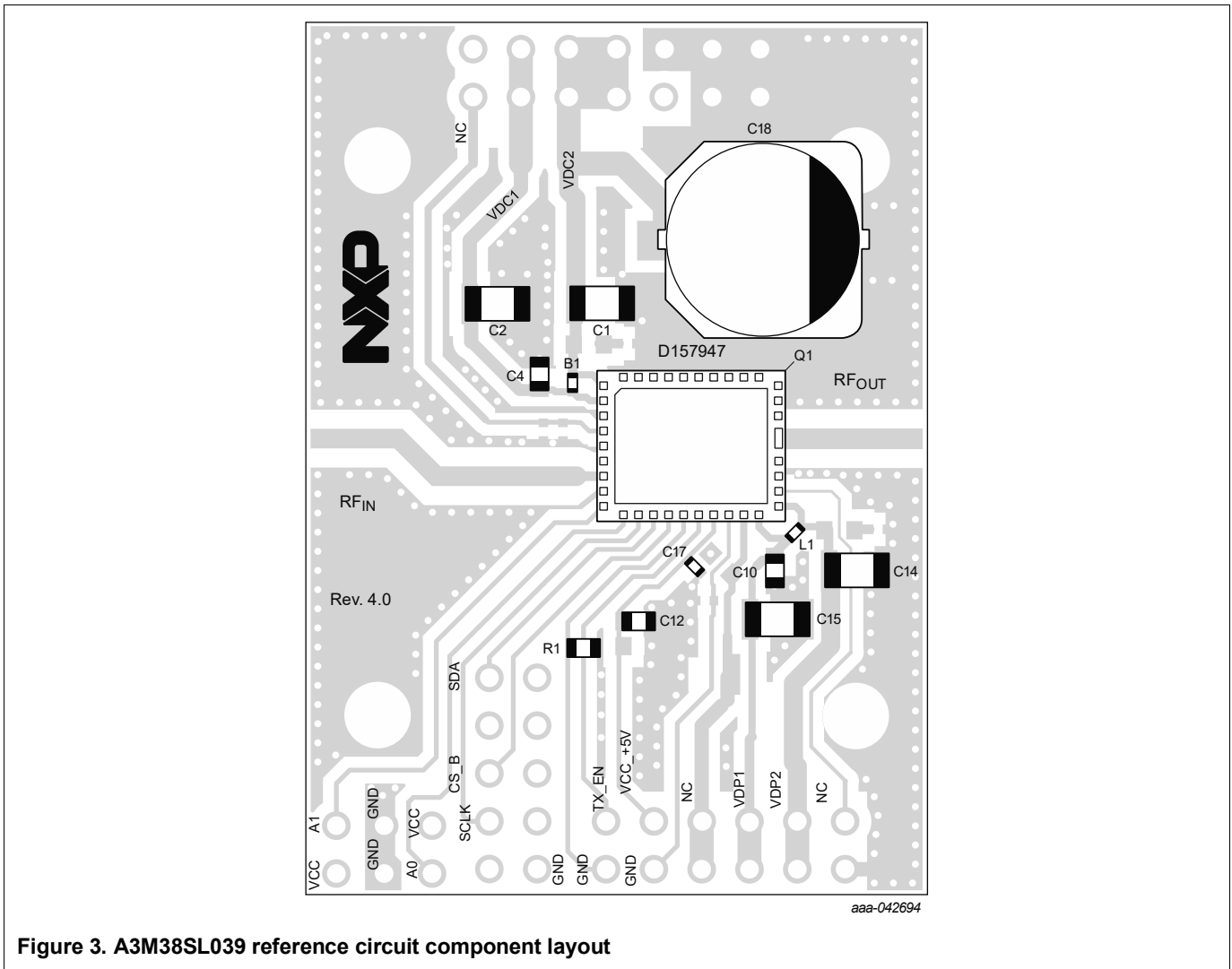

Figure 3. A3M38SL039 reference circuit component layout

10.2 Component designations and values

Table 16. A3M38SL039 reference circuit component designations and values

Part	Description	Part Number	Manufacturer
B1	30 Ω Ferrite Bead	BLM15PD300SN1	Murata
C1, C2, C14, C15	10 μF Chip Capacitor	GRM31CR61H106KA12	Murata
C4, C10, C12	1 μF Chip Capacitor	GRM188R61H105KAAL	Murata
C17	1000 pF Chip Capacitor	GRM022R71A102KA12L	Murata
C18	220 μF, 50 V Electrolytic Capacitor	UUJ1H221M1NQ1MS	Nichicon
L1	13 nH Chip Inductor	LQW15AN13NG80D	Murata
Q1	Power Amplifier Module	A3M38SL039	NXP
R1	0 Ω, 1/8 W Chip Resistor	CRCW08050000Z0EA	Vishay
PCB	Rogers RO4350B, 0.020", ε _r = 3.66	D157947	MTL

Note: Component numbers C3, C5, C6, C7, C8, C9, C11, C13 and C16 are intentionally omitted.

11 Temperature sensor

The temperature value is converted from the 8-bit temperature sense ADC value (stored in the Temp_ADC register) via the following equation.

$$\text{Temperature (}^\circ\text{C)} = (0.67798 \times \text{Temp_ADC}) - 36.64$$

A plot of this equation is shown in [Figure 4](#).

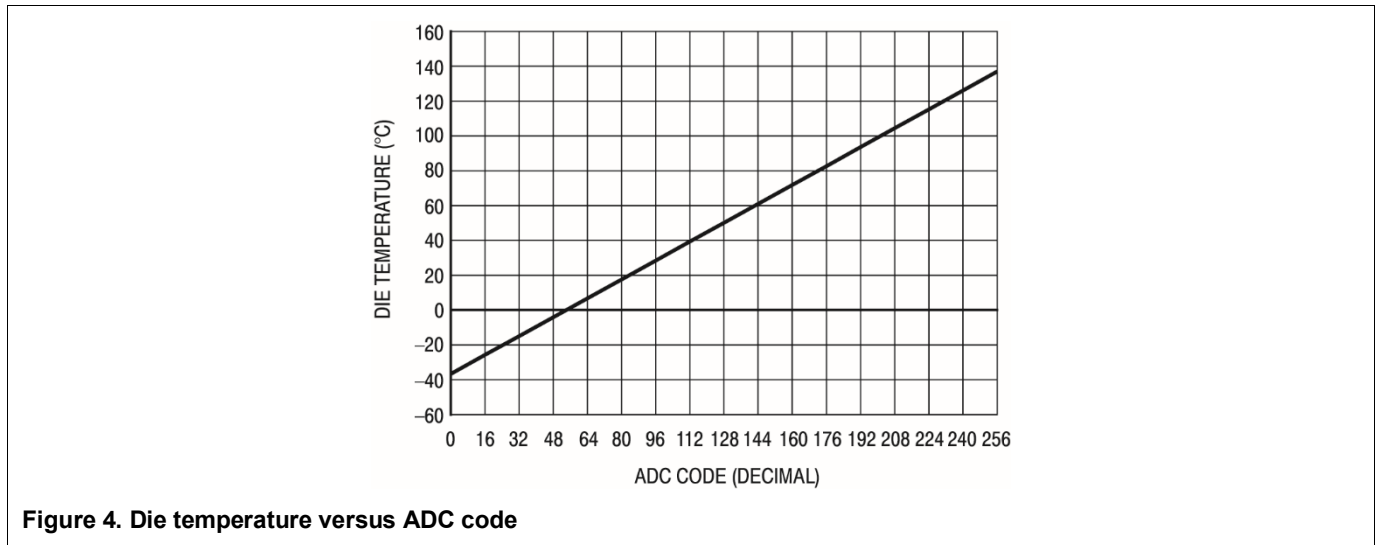

Figure 4. Die temperature versus ADC code

Table 17. Temperature sensor accuracy

Characteristic	Value	Unit
Operating Die Temperature, T _J = 25°C to 125°C	±3	°C
Operating Die Temperature, T _J = -35°C to 125°C	±5	°C

12 Communication interface

The A3M38SL039 device contains a digital interface that supports a 2-pin I²C interface. The digital interface is used to both read and write data to and from the device. The preferred interface type must be set at the factory prior to shipment. For I²C functionality, order part number A3M38SL039I.

12.1 I²C

The A3M38SL039I follows the I²C protocol standard. It supports I²C fast mode with a bit rate up to 400 Kbit/s. It also supports I²C standard mode with bit rate up to 100 Kbit/s.

12.1.1 I²C addressing

The two external tri-state address pins A0 and A1 use 5 V logic levels and are decoded into 7-bit I²C addresses as shown in [Table 18](#). The three LSBs of the 7-bit address are set via the A0 and A1 pins. The four MSBs are the base address, which is fixed at 1000.

Table 18. I²C 7-bit address assignment

A1	A0	I ² C 7-Bit Address
0	0	Not Translated
0	Z	1000 000
0	1	1000 001
Z	0	1000 010
Z	Z	1000 011
Z	1	1000 100
1	0	1000 101
1	Z	1000 110
1	1	1000 111

12.1.2 I²C instruction set

12.1.2.1 I²C Write instruction

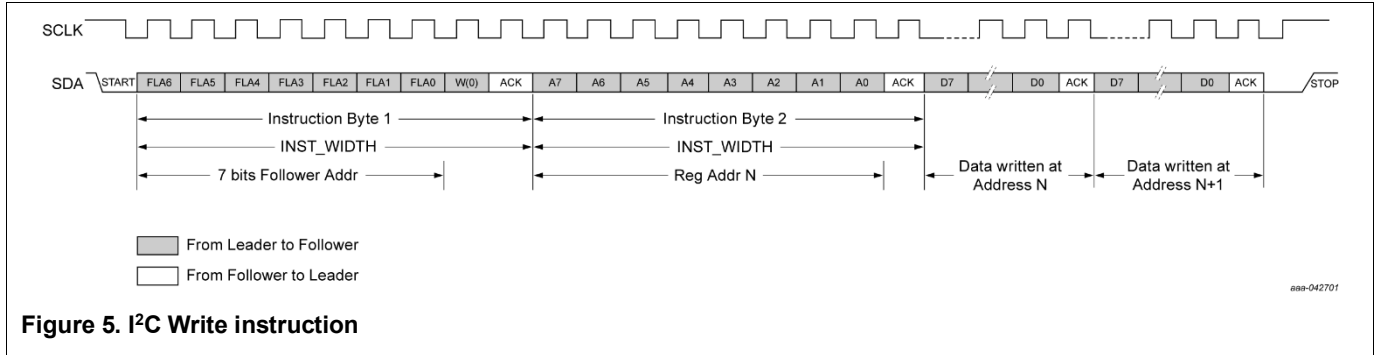

Figure 5. I²C Write instruction

12.1.2.2 I²C Read instruction

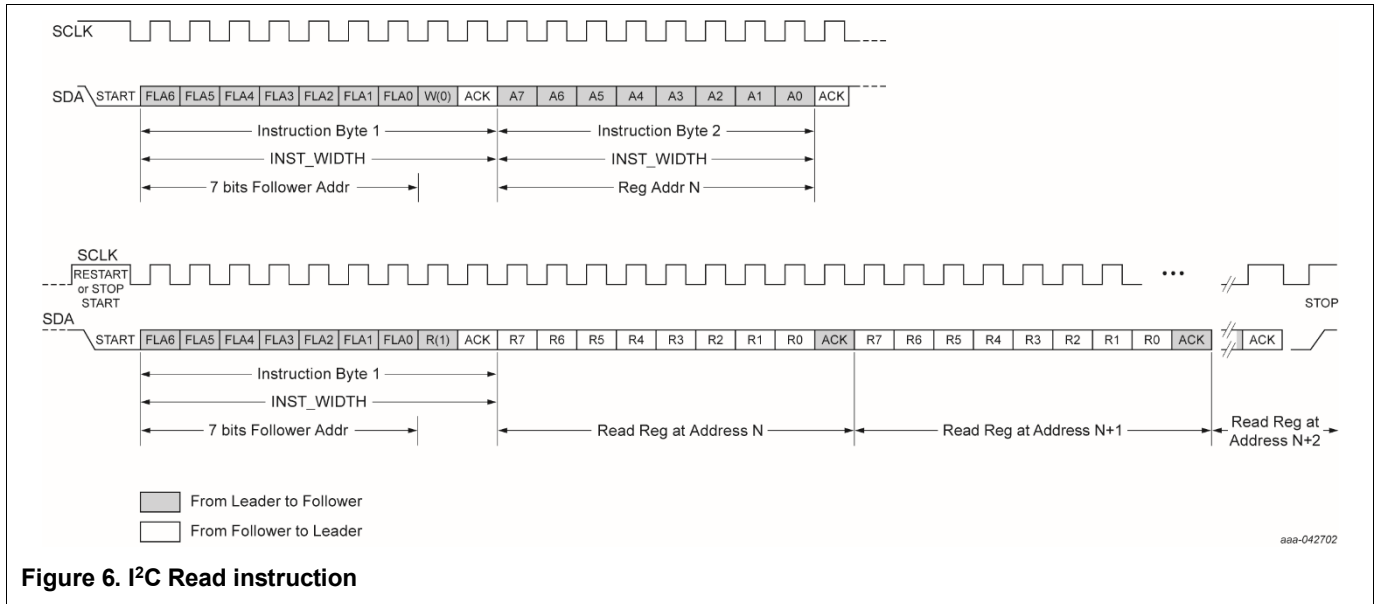

Figure 6. I²C Read instruction

12.1.2.3 I²C Write and Read combination sequence

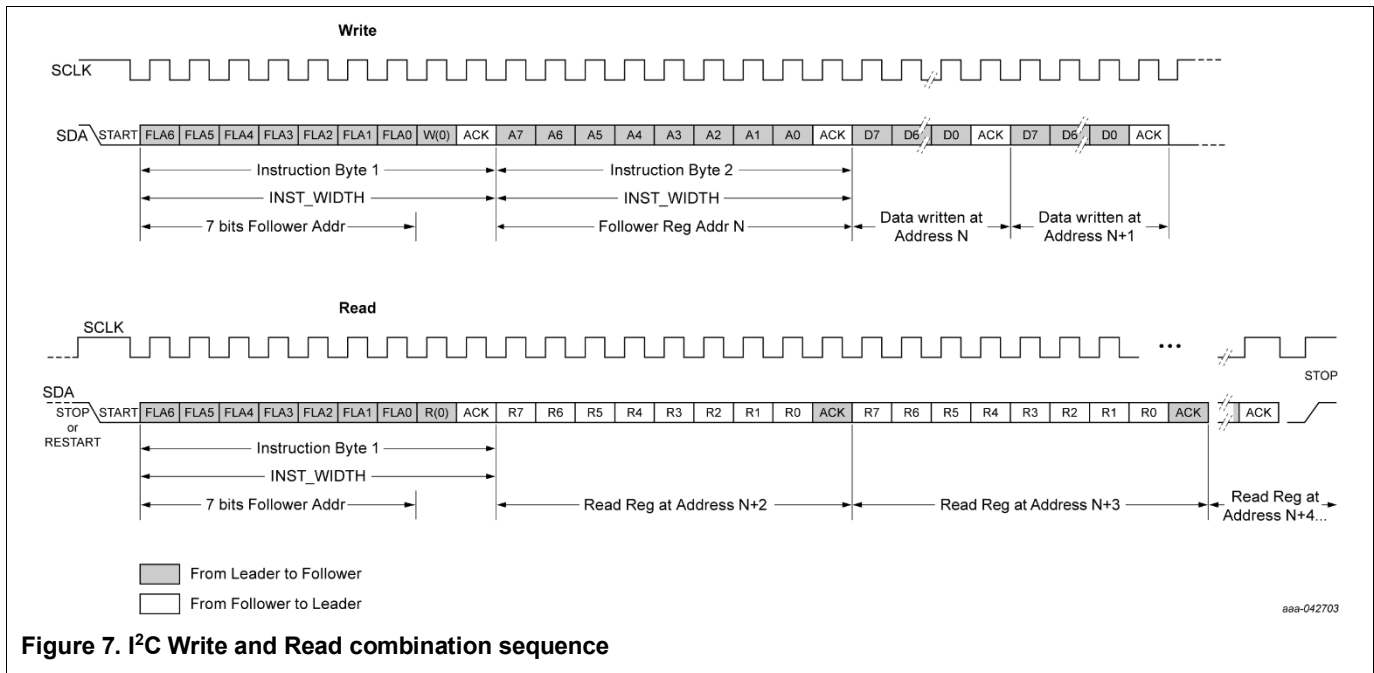

Figure 7. I²C Write and Read combination sequence

12.1.3 I²C Device ID Read instruction

The Device ID is read only, hardwired in the device and can be accessed as follows:

1. START condition
2. The leader sends the Reserved Device ID I²C bus address followed by the R/W bit set to '0' (write): '1111 1000'.
3. The leader sends the I²C bus follower address of the follower device it must identify. The LSB is a "don't care" value. Only one device must acknowledge this byte (the device that has the I²C bus follower address).
4. The leader sends a RESTART condition.

Remark: A STOP condition followed by a START condition resets the follower state machine and the Device ID read cannot be performed. Also, a STOP condition or a RESTART condition followed by an access to another follower device resets the follower state machine and the Device ID read cannot be performed.

1. The leader sends the Reserved Device ID I²C bus address followed by the R/W bit set to '1' (read): '1111 1001'.
2. The Device ID read can be completed, starting with the 12 manufacturer bits (first byte + four MSBs of the second byte), followed by the nine part identification bits (four LSBs of the second byte + five MSBs of the third byte), and then the three die revision bits (three LSBs of the third byte).
3. The leader ends the reading sequence by NACKing the last byte, thus resetting the follower device state machine and allowing the leader to send the STOP condition.

Remark: The reading of the Device ID can be stopped anytime by sending a NACK.

Table 19. I²C Device Read instructions

Leader to Follower	Leader to Follower	Leader to Follower	Leader to Follower	Leader to Follower	Follower to Leader	Leader to Follower	Leader to Follower
START	1111 1000	XXXXXXXX+'0/1'	RESTART	1111 1001	3 bytes ID	NACK	STOP

12.2 I²C electrical specification and timing for I/O stages and bus lines

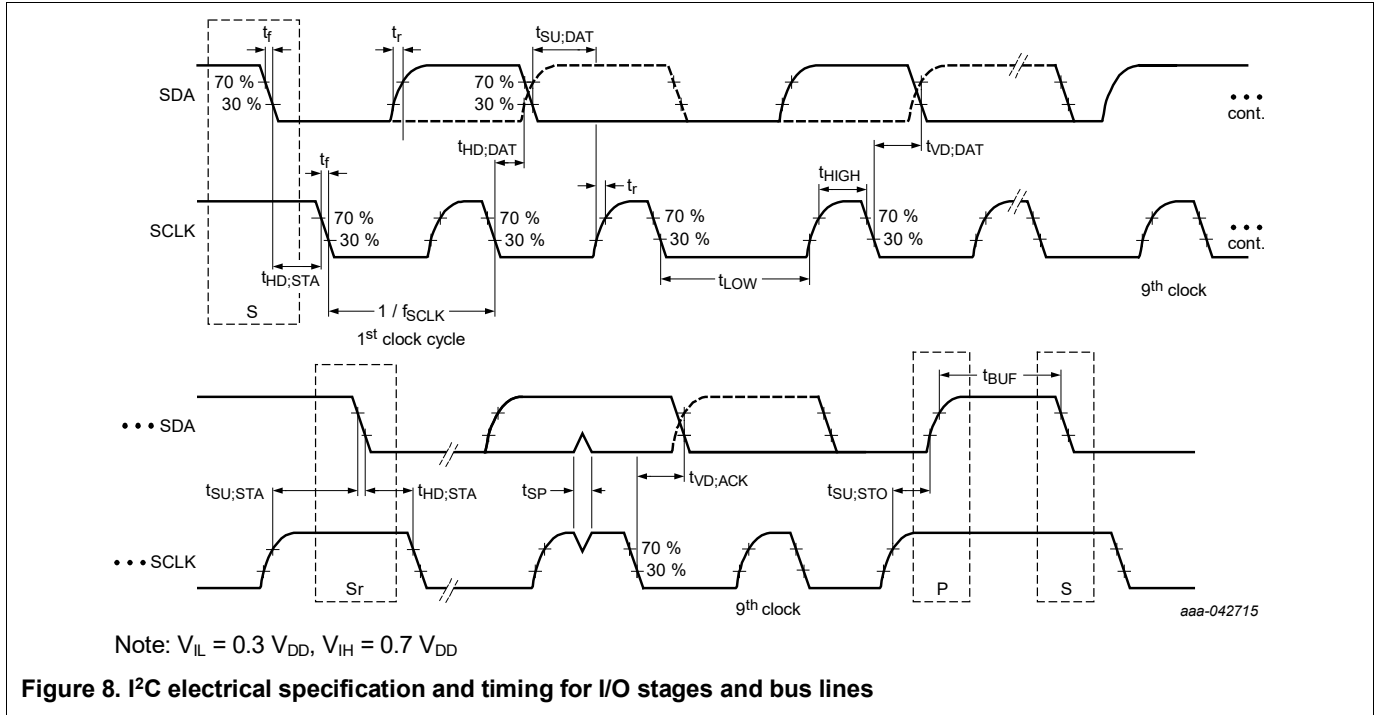

12.2.1 I²C SCLK and SDA characteristicsTable 20. I²C SCLK and SDA

Symbol	Parameter	Conditions	Min	Max	Unit
f _{SCLK}	SCLK clock frequency	—	0	400	kHz
t _{HD,STA}	Hold time (repeated) START condition	After this period, the first clock pulse is generated.	0.6	—	μs
t _{LOW}	Low period of the SCLK clock ^[1]	—	1.3	—	μs
t _{HIGH}	High Period of the SCLK clock	—	0.6	—	μs
t _{SU,STA}	Setup time for a repeated START condition	—	0.6	—	μs
t _{HD,STA}	Data hold time ^[2]	BBUS-compatible masters	—	—	μs
		I ² C bus devices	0	—	μs
t _{SU,STA}	Data setup time	—	100 ^[3]	—	μs
t _r	Rise time of both SDA and SCLK signals	—	20	300	ns
t _f	Fall time of both SDA and SCLK signals ^{[4][5][6]}	—	6.5	300	ns
t _{SU,STA}	Setup time for STOP condition	—	0.6	—	μs
t _{BUF}	Bus free time between a STOP and START condition	—	1.3	—	μs
t _{VD,DAT}	Data valid time ^[7]	—	—	0.9	μs
t _{VD,ACK}	Data valid acknowledge time ^[6]	—	—	0.9	μs

[1] Note: All values referred to V_{IH(min)} (0.3 V_{DD}) and V_{IL(max)} (0.7 V_{DD}) level.

[2] t_{HD,DAT} is the data hold time that is measured from the falling edge of SCLK and applies to data in transmission and the Acknowledge.

[3] A fast mode I²C bus device can be used in a standard mode I²C bus system, but the requirement t_{SU,DAT} 250 ns must then be met. This is automatically the case if the device does not stretch the LOW period of the SCLK signal. If such a device does not stretch the LOW period of the SCLK signal, it must output the next data bit to the SDA line t_{r(max)} + t_{SU,DATA} = 1000 + 250 = 1250 ns (according to the Standard Mode I²C Bus Specification) before the SCLK line is released. Also the Acknowledge timing must meet this setup time.

[4] A device must internally provide a hold time of at least 300 ns for the SDA signal (with respect to the V_{IH(min)} of the SCLK signal) to bridge the undefined region of the falling edge of SCLK.

[5] The maximum t_{HD,DAT} could be 3.45 μs and 0.9 μs for standard mode and fast mode, but must be less than the maximum of t_{VD,DAT} or t_{VD,ACK} by a transition time. This maximum must only be met if the device does not stretch the LOW period (t_{LOW}) of the SCLK signal. If the clock stretches the SCLK, the data must be valid by the setup mode before it releases the clock.

[6] t_{VD,ACK} = time for Acknowledgement signal from SCLK LOW to SDA output (HIGH or LOW, depending on which one is longer).

[7] t_{VD,DAT} = time for data signal from SCLK LOW to SDA output (HIGH or LOW, depending on which one is longer).

12.2.2 I²C bus electrical characteristics

Table 21. I²C SCLK and SDA

Symbol	Parameter	Conditions	Min	Max	Unit
V _{IL}	LOW-level input voltage	—	—	0.3*V _{DD} ^[1]	V
V _{IH}	HIGH-level input voltage	—	0.7*V _{DD} ^[1]	—	V
V _{hys}	Hysteresis of Schmitt trigger inputs	—	0.05*V _{DD} ^[1]	—	V
V _{OL}	LOW-level output voltage	(Open-drain/open-collector) at 2 mA sink current V _{DD} ^[1] = < 2 V	0	0.2*V _{DD} ^[1]	V
V _{OH}	HIGH-level output voltage	(Open-drain/open-collector)	0.7*V _{DD} ^[1]	V _{DD} ^[1]	V
I _{OL}	LOW-level output current	V _{OL} = 0.4 V	3	—	mA
		V _{OL} = 0.6 V	6	—	mA
I _{iL}	Input leakage current at the pin	V _{DD} = 1.8, Pin voltage = 1.8 V, 0.1 V _{DD} < V _I < 0.9 V _{DD} ^[1]	-10	10	μA
C _i	Capacitance for each I/O pin	—	—	10	pF
t _{SP}	Pulse width of spikes that must be suppressed by the input filter	—	0	50	ns
t _{of}	Output fall time from V _{IH(min)} to V _{IL(max)}	Pullup res = 250 ohm and max allowed load capacitance C _b	—	250	ns
C _b	Capacitive load for each bus line ^[2]	—	—	400	pF

[1] V_{DD} in this table refers to 1.8 V provided by the Leader.

[2] The maximum t_f for the SDA and SCLK bus lines is specified at 300 ns. This allows series protection resistors to be connected in between the SDA and the SCLK pins and the SCLK bus lines without exceeding the maximum specified t_f.

13 Design considerations

13.1 Power on sequence

The initial power on sequence will take approximately 200 μs to complete the OTP memory fetching process. Therefore, it is suggested to wait at least 200 μs before issuing the I²C read and write processes. The normal I²C read and write processes should follow the sequence illustrated in Figure 9, “Power on sequence timing diagram.”

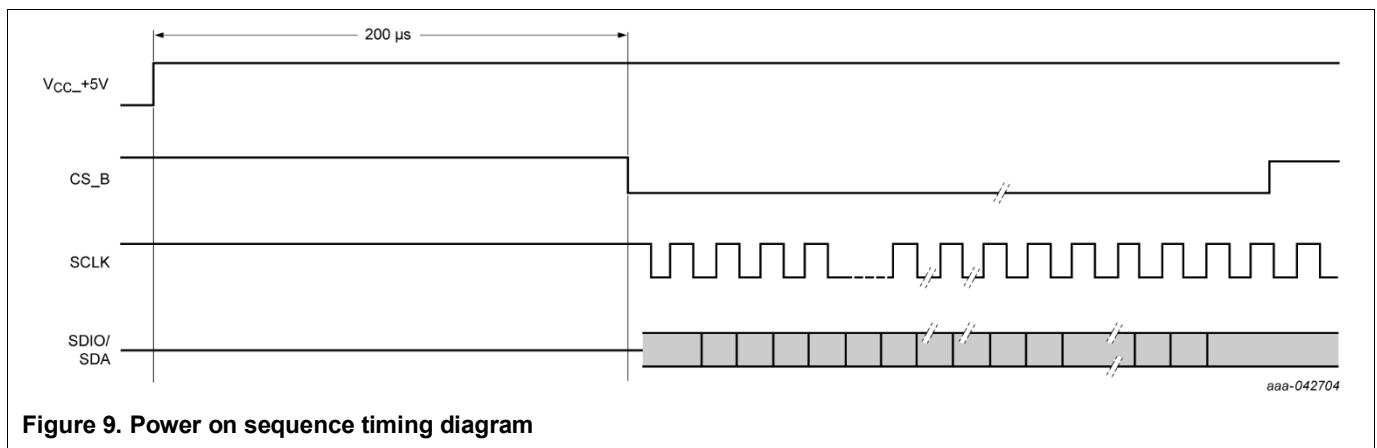

Figure 9. Power on sequence timing diagram

13.2 Programming guidelines to avoid hardware failure or damage

Users must be aware of the following guidelines to avoid potential hardware failure or damage.

- Do not program the Refresh OTP and Soft Reset bits to a 1 state at the same time.
- Soft Reset bit will reset Engineering Mode (EM).
- The Soft Reset bit is easily accessible; therefore, be cautious of the accidental reset.
- Tx_EN must not be active during an OTP refresh or during Engineering Mode.

13.3 Group programming

Figure 10 illustrates group programming for A3M38SL039; each device can be controlled and programmed based on its assigned individual I²C address.

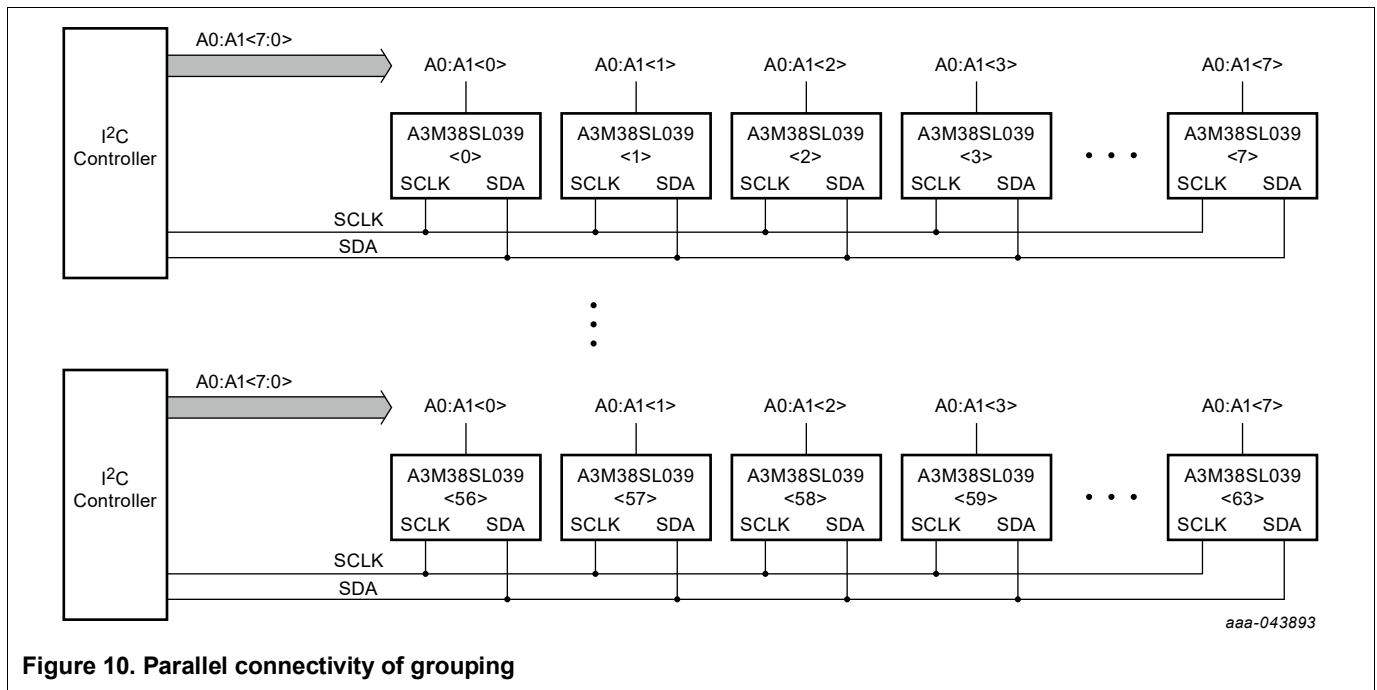

14 Product marking



15 Package information

H-FC-PLGA-38 I/O
10 X 8 X 1.365 PKG, 0.8 PITCH

SOT2059-1

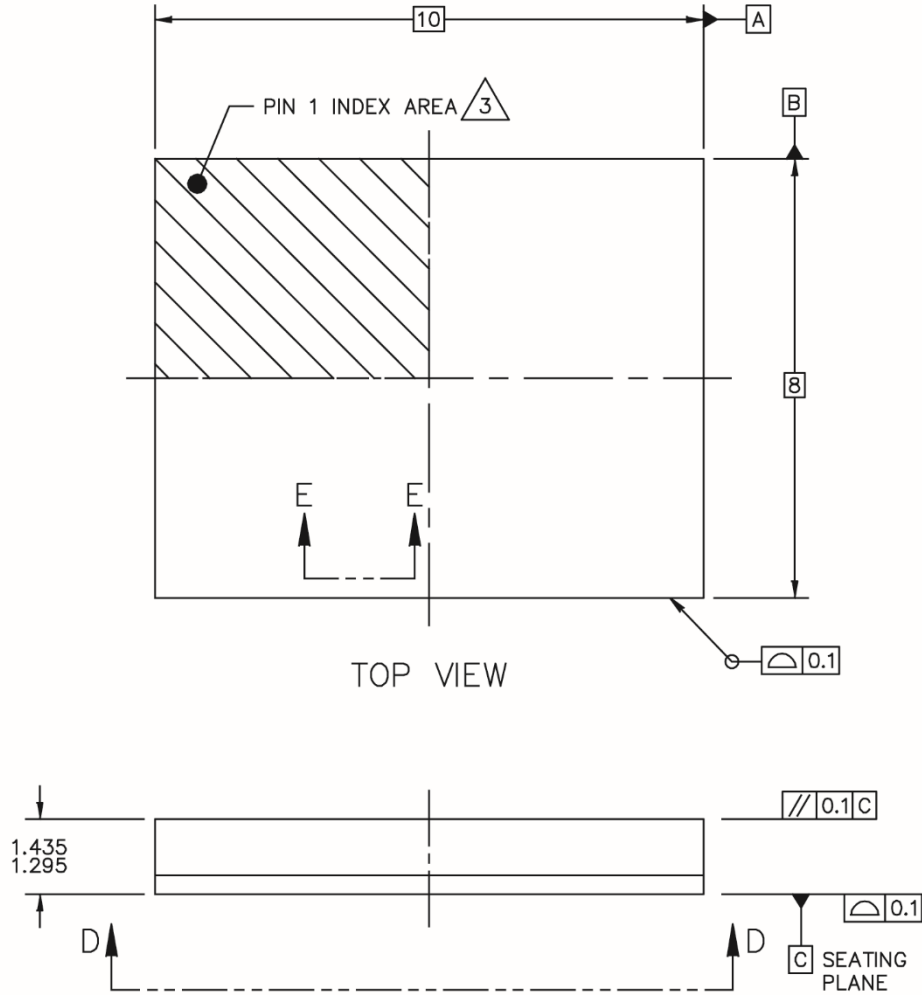

© NXP B.V. ALL RIGHTS RESERVED

DATE: 27 MAR 2020

MECHANICAL OUTLINE PRINT VERSION NOT TO SCALE	STANDARD: NON-JEDEC	DRAWING NUMBER: 98ASA01589D	REVISION: 0	PAGE: 1 OF 6
--	------------------------	--------------------------------	----------------	-----------------

Figure 12. Package information

H-FC-PLGA-38 I/O
10 X 8 X 1.365 PKG, 0.8 PITCH

SOT2059-1

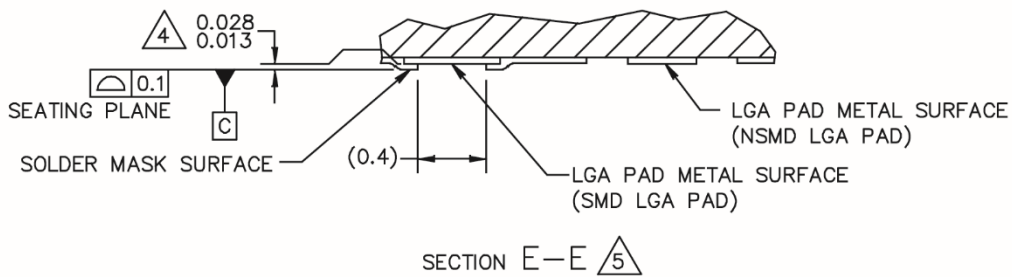
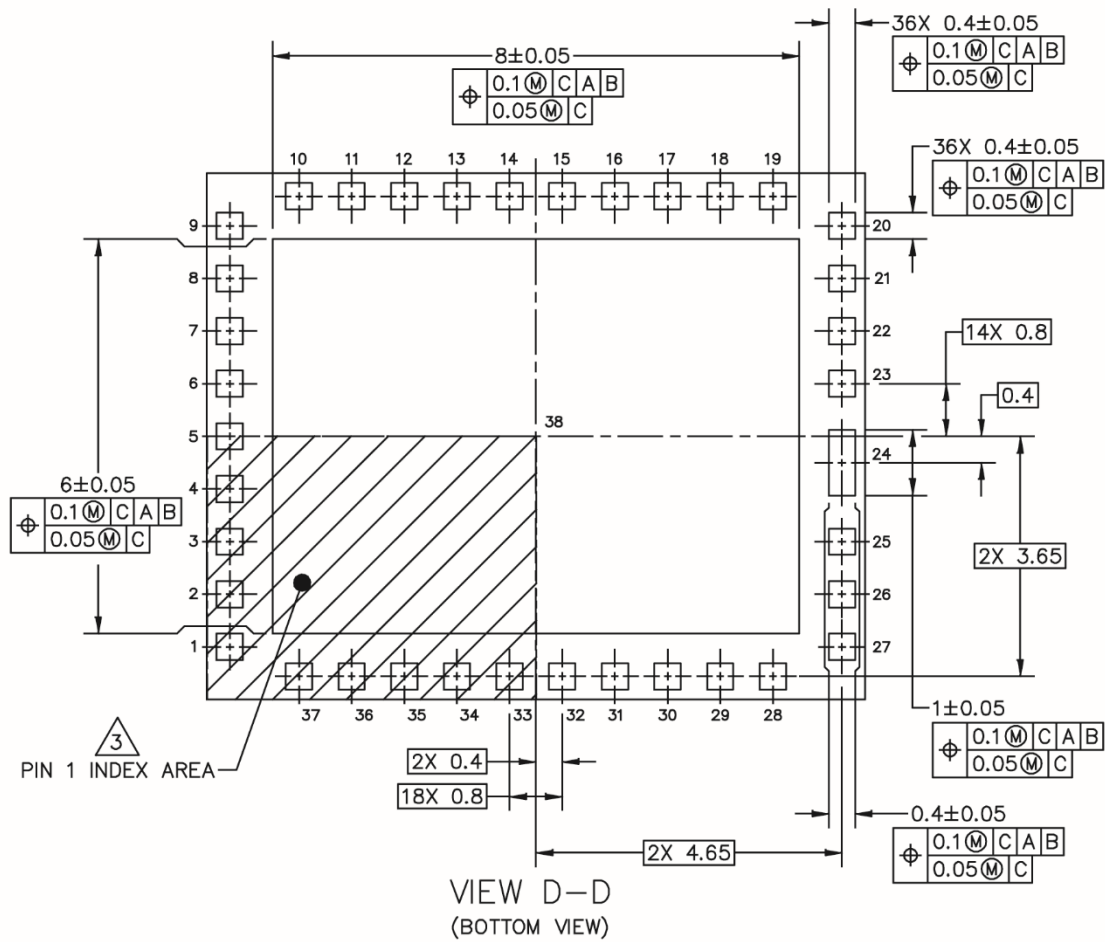

© NXP B.V. ALL RIGHTS RESERVED

MECHANICAL OUTLINE PRINT VERSION NOT TO SCALE	STANDARD: NON-JEDEC	DRAWING NUMBER: 98ASA01589D
		DATE: 27 MAR 2020
		REVISION: 0
		PAGE: 2

Figure 12. Package information

H-FC-PLGA-38 I/O
10 X 8 X 1.365 PKG, 0.8 PITCH

SOT2059-1

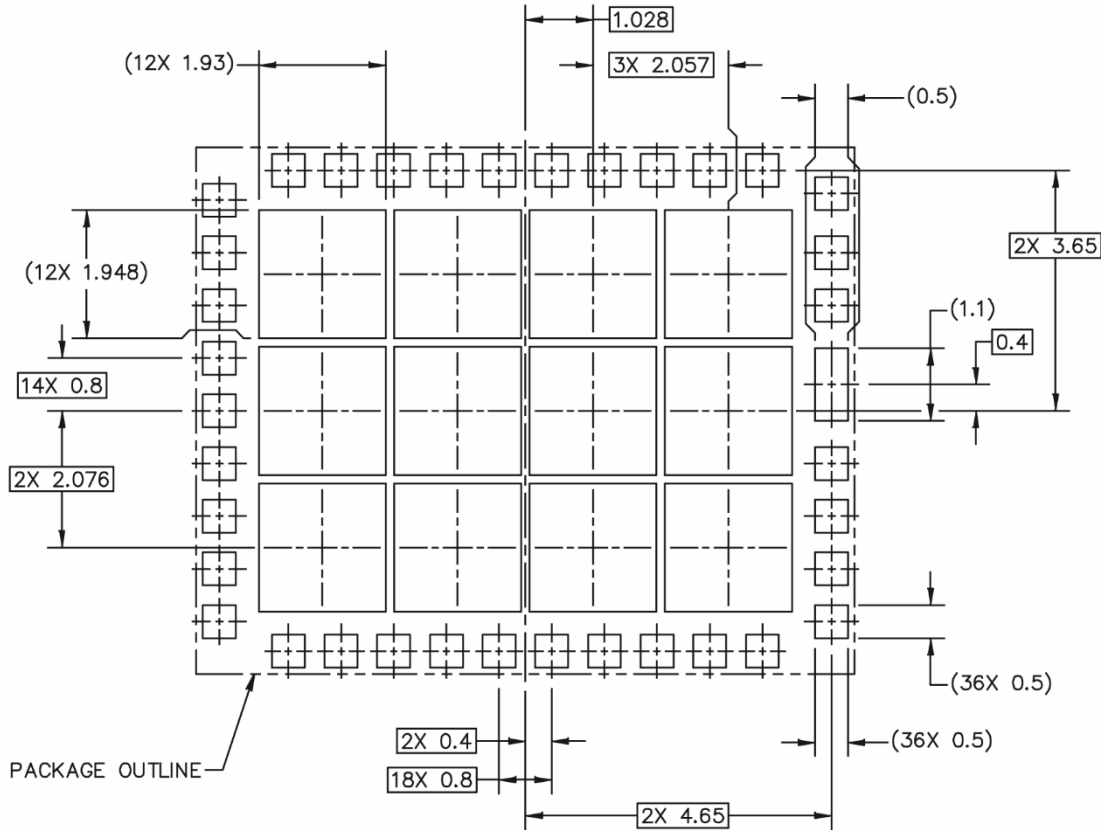

PCB DESIGN GUIDELINES – SOLDER MASK OPENING PATTERN

THIS SHEET SERVES ONLY AS A GUIDELINE TO HELP DEVELOP A USER SPECIFIC SOLUTION. DEVELOPMENT EFFORT WILL STILL BE REQUIRED BY END USERS TO OPTIMIZE PCB MOUNTING PROCESSES AND BOARD DESIGN IN ORDER TO MEET INDIVIDUAL/SPECIFIC REQUIREMENTS.

© NXP B.V. ALL RIGHTS RESERVED

DATE: 27 MAR 2020

MECHANICAL OUTLINE PRINT VERSION NOT TO SCALE	STANDARD: NON-JEDEC	DRAWING NUMBER: 98ASA01589D	REVISION: 0	PAGE: 3
--	------------------------	--------------------------------	----------------	------------

Figure 12. Package information

H-FC-PLGA-38 I/O
10 X 8 X 1.365 PKG, 0.8 PITCH

SOT2059-1

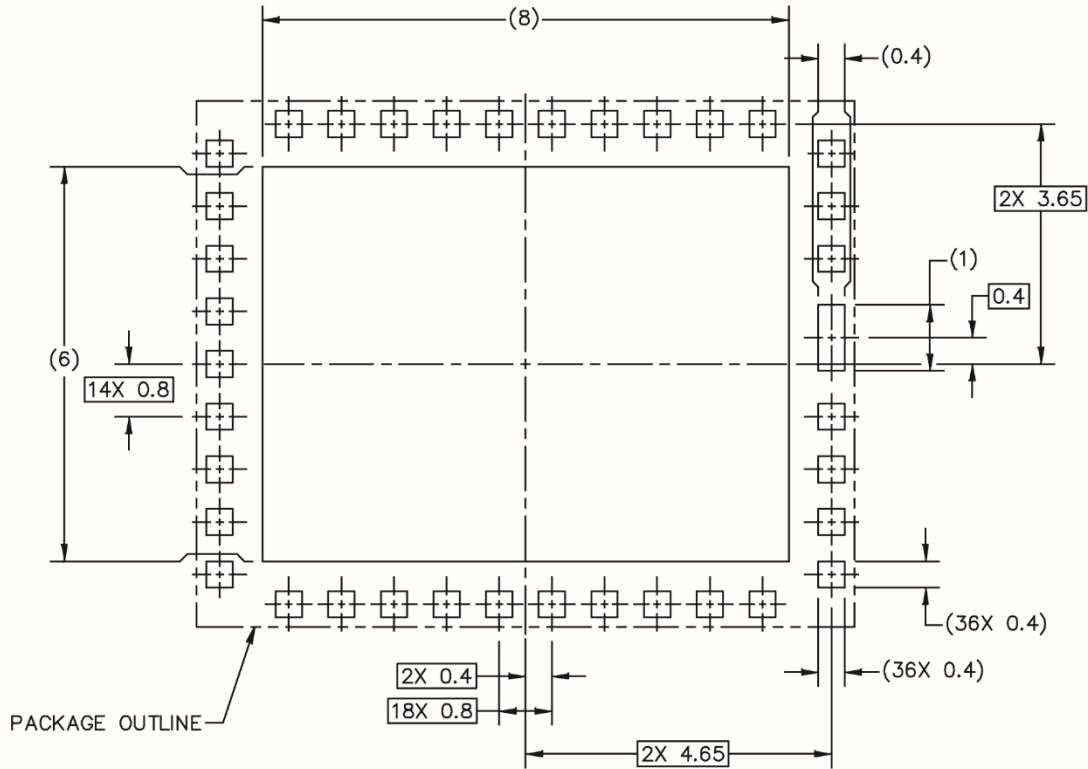

PCB DESIGN GUIDELINES – I/O PADS AND SOLDERABLE AREAS

THIS SHEET SERVES ONLY AS A GUIDELINE TO HELP DEVELOP A USER SPECIFIC SOLUTION. DEVELOPMENT EFFORT WILL STILL BE REQUIRED BY END USERS TO OPTIMIZE PCB MOUNTING PROCESSES AND BOARD DESIGN IN ORDER TO MEET INDIVIDUAL/SPECIFIC REQUIREMENTS.

© NXP B.V. ALL RIGHTS RESERVED

DATE: 27 MAR 2020

MECHANICAL OUTLINE PRINT VERSION NOT TO SCALE	STANDARD: NON-JEDEC	DRAWING NUMBER: 98ASA01589D	REVISION: 0	PAGE: 4
--	------------------------	--------------------------------	----------------	------------

Figure 12. Package information

H-FC-PLGA-38 I/O
10 X 8 X 1.365 PKG, 0.8 PITCH

SOT2059-1

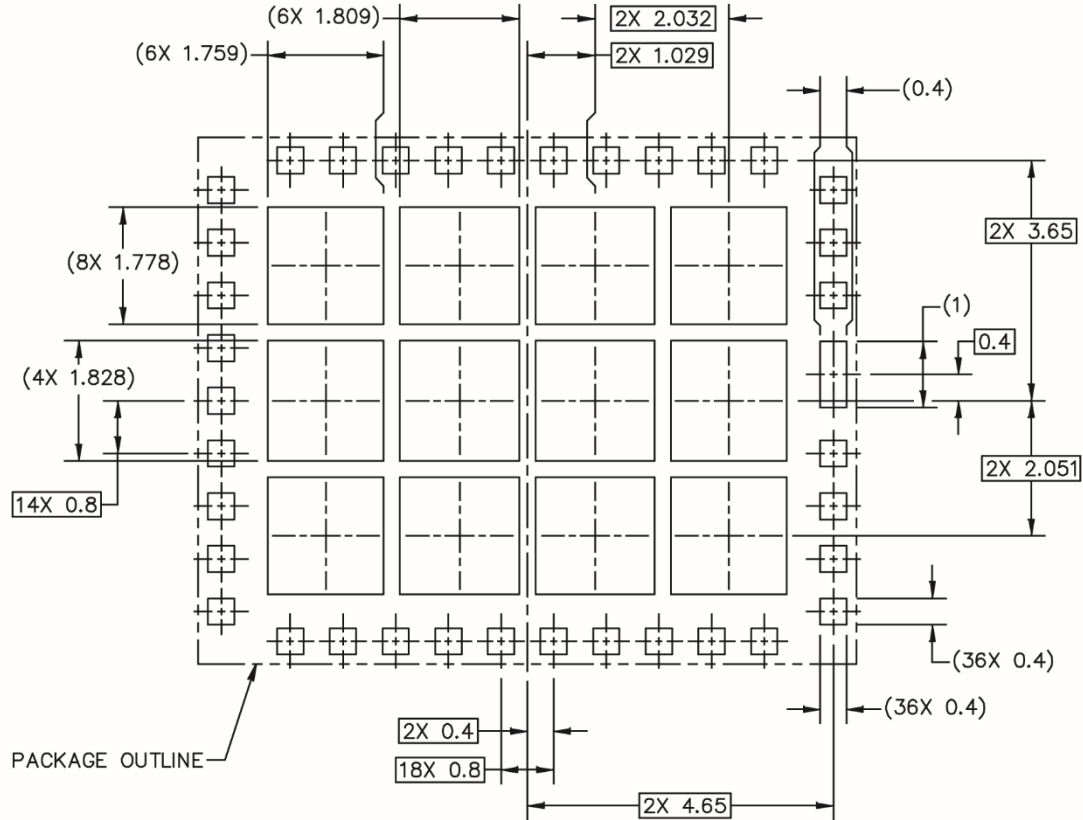

RECOMMENDED STENCIL THICKNESS 0.125

PCB DESIGN GUIDELINES – SOLDER PASTE STENCIL

THIS SHEET SERVES ONLY AS A GUIDELINE TO HELP DEVELOP A USER SPECIFIC SOLUTION. DEVELOPMENT EFFORT WILL STILL BE REQUIRED BY END USERS TO OPTIMIZE PCB MOUNTING PROCESSES AND BOARD DESIGN IN ORDER TO MEET INDIVIDUAL/SPECIFIC REQUIREMENTS.

© NXP B.V. ALL RIGHTS RESERVED

DATE: 27 MAR 2020

MECHANICAL OUTLINE PRINT VERSION NOT TO SCALE	STANDARD: NON-JEDEC	DRAWING NUMBER: 98ASA01589D	REVISION: 0	PAGE: 5
--	------------------------	--------------------------------	----------------	------------

Figure 12. Package information

H-FC-PLGA-38 I/O
10 X 8 X 1.365 PKG, 0.8 PITCH

SOT2059-1

NOTES:

1. ALL DIMENSIONS IN MILLIMETERS.
2. DIMENSIONING AND TOLERANCING PER ASME Y14.5M-1994.
3. PIN 1 FEATURE SHAPE, SIZE AND LOCATION MAY VARY.
4. DIMENSION APPLIES TO ALL LEADS AND FLAG.
5. THE BOTTOM VIEW SHOWS THE SOLDERABLE AREA OF THE PADS. THE CENTER PAD (PIN 38) IS SOLDER MASK DEFINED. SOME PERIPHERAL PADS ARE SOLDER MASK DEFINED (SMD) AND OTHERS ARE NON-SOLDERMASK DEFINED (NSMD).

© NXP B.V. ALL RIGHTS RESERVED

DATE: 27 MAR 2020

MECHANICAL OUTLINE PRINT VERSION NOT TO SCALE	STANDARD: NON-JEDEC	DRAWING NUMBER: 98ASA01589D	REVISION: 0	PAGE: 6
--	------------------------	--------------------------------	----------------	------------

Figure 12. Package information

16 Product software and tools

Refer to the following resources to aid your design process.

Development Software

- Demo Software

Development Tools

- Printed Circuit Boards

17 Failure analysis

At this time, because of the physical characteristics of the part, failure analysis is limited to electrical signature analysis. In cases where NXP is contractually obligated to perform failure analysis (FA) services, full FA may be performed by third party vendors with moderate success. For updates contact your local NXP Sales Office.

18 Revision history

The following table summarizes revisions to this document.

Table 22. Revision history

Document ID	Release date	Description
A3M38SL039 Rev. 1	1 July 2024	<ul style="list-style-type: none">• Removed references to SPI• Tables 8 and 9, Functional Tests, 3600 MHz and 4000 MHz: updated output power test condition, p. 5• Product software: updated category name, p. 29
A3M38SL039 Rev. 0	23 September 2022	<ul style="list-style-type: none">• Initial release of product data sheet

Legal information

Data sheet status

Document status ^{[1][2]}	Product status ^[3]	Definition
Objective [short] data sheet	Development	This document contains data from the objective specification for product development.
Preliminary data sheet	Qualification	This document contains data from the preliminary specification.
Product [short] data sheet	Production	This document contains the product specification.

[1] Please consult the most recently issued document before initiating or completing a design.

[2] The term 'short data sheet' is explained in section "Definitions".

[3] The product status of device(s) described in this document may have changed since this document was published and may differ in case of multiple devices. The latest product status information is available on the Internet at URL <https://www.nxp.com>.

Definitions

Draft — A draft status on a document indicates that the content is still under internal review and subject to formal approval, which may result in modifications or additions. NXP Semiconductors does not give any representations or warranties as to the accuracy or completeness of information included in a draft version of a document and shall have no liability for the consequences of use of such information.

Short data sheet — A short data sheet is an extract from a full data sheet with the same product type number(s) and title. A short data sheet is intended for quick reference only and should not be relied upon to contain detailed and full information. For detailed and full information see the relevant full data sheet, which is available on request via the local NXP Semiconductors sales office. In case of any inconsistency or conflict with the short data sheet, the full data sheet shall prevail.

Product specification — The information and data provided in a Product data sheet shall define the specification of the product as agreed between NXP Semiconductors and its customer, unless NXP Semiconductors and customer have explicitly agreed otherwise in writing. In no event however, shall an agreement be valid in which the NXP Semiconductors product is deemed to offer functions and qualities beyond those described in the Product data sheet.

Disclaimers

Limited warranty and liability — Information in this document is believed to be accurate and reliable. However, NXP Semiconductors does not give any representations or warranties, expressed or implied, as to the accuracy or completeness of such information and shall have no liability for the consequences of use of such information. NXP Semiconductors takes no responsibility for the content in this document if provided by an information source outside of NXP Semiconductors.

In no event shall NXP Semiconductors be liable for any indirect, incidental, punitive, special or consequential damages (including - without limitation - lost profits, lost savings, business interruption, costs related to the removal or replacement of any products or rework charges) whether or not such damages are based on tort (including negligence), warranty, breach of contract or any other legal theory.

Notwithstanding any damages that customer might incur for any reason whatsoever, NXP Semiconductors' aggregate and cumulative liability towards customer for the products described herein shall be limited in accordance with the Terms and conditions of commercial sale of NXP Semiconductors.

Right to make changes — NXP Semiconductors reserves the right to make changes to information published in this document, including without limitation specifications and product descriptions, at any time and without notice. This document supersedes and replaces all information supplied prior to the publication hereof.

Suitability for use — NXP Semiconductors products are not designed, authorized or warranted to be suitable for use in life support, life-critical or safety-critical systems or equipment, nor in applications where failure or malfunction of an NXP Semiconductors product can reasonably be expected to result in personal injury, death or severe property or environmental damage. NXP Semiconductors and its suppliers accept no liability for inclusion and/or use of NXP Semiconductors products in such equipment or applications and therefore such inclusion and/or use is at the customer's own risk.

Applications — Applications that are described herein for any of these products are for illustrative purposes only. NXP Semiconductors makes no representation or warranty that such applications will be suitable for the specified use without further testing or modification.

Customers are responsible for the design and operation of their applications and products using NXP Semiconductors products, and NXP Semiconductors accepts no liability for any assistance with applications or customer product design. It is customer's sole responsibility to determine whether the NXP Semiconductors product is suitable and fit for the customer's applications and products planned, as well as for the planned application and use of customer's third party customer(s). Customers should provide appropriate design and operating safeguards to minimize the risks associated with their applications and products.

NXP Semiconductors does not accept any liability related to any default, damage, costs or problem which is based on any weakness or default in the customer's applications or products, or the application or use by customer's third party customer(s). Customer is responsible for doing all necessary testing for the customer's applications and products using NXP Semiconductors products in order to avoid a default of the applications and the products or of the application or use by customer's third party customer(s). NXP does not accept any liability in this respect.

Limiting values — Stress above one or more limiting values (as defined in the Absolute Maximum Ratings System of IEC 60134) will cause permanent damage to the device. Limiting values are stress ratings only and (proper) operation of the device at these or any other conditions above those given in the Recommended operating conditions section (if present) or the Characteristics sections of this document is not warranted. Constant or repeated exposure to limiting values will permanently and irreversibly affect the quality and reliability of the device.

Terms and conditions of commercial sale — NXP Semiconductors products are sold subject to the general terms and conditions of commercial sale, as published at <https://www.nxp.com/profile/terms>, unless otherwise agreed in a valid written individual agreement. In case an individual agreement is concluded only the terms and conditions of the respective agreement shall apply. NXP Semiconductors hereby expressly objects to applying the customer's general terms and conditions with regard to the purchase of NXP Semiconductors products by customer.

No offer to sell or license — Nothing in this document may be interpreted or construed as an offer to sell products that is open for acceptance or the grant, conveyance or implication of any license under any copyrights, patents or other industrial or intellectual property rights.

Export control — This document as well as the item(s) described herein may be subject to export control regulations. Export might require a prior authorization from competent authorities.

Suitability for use in non-automotive qualified products — Unless this document expressly states that this specific NXP Semiconductors product is automotive qualified, the product is not suitable for automotive use. It is neither qualified nor tested in accordance with automotive testing or application requirements. NXP Semiconductors accepts no liability for inclusion and/or use of non-automotive qualified products in automotive equipment or applications.

In the event that customer uses the product for design-in and use in automotive applications to automotive specifications and standards, customer (a) shall use the product without NXP Semiconductors' warranty of the product for such automotive applications, use and specifications, and (b) whenever customer uses the product for automotive applications beyond NXP Semiconductors' specifications such use shall be solely at customer's own risk, and (c) customer fully indemnifies NXP Semiconductors for any liability, damages or failed product claims resulting from customer design and use of the product for automotive applications beyond NXP Semiconductors' standard warranty and NXP Semiconductors' product specifications.

Translations — A non-English (translated) version of a document, including the legal information in that document, is for reference only. The English version shall prevail in case of any discrepancy between the translated and English versions.

Security — Customer understands that all NXP products may be subject to unidentified vulnerabilities or may support established security standards or specifications with known limitations. Customer is responsible for the design and operation of its applications and products throughout their lifecycles to reduce the effect of these vulnerabilities on customer's applications and products. Customer's responsibility also extends to other open and/or proprietary technologies supported by NXP products for use in customer's applications. NXP accepts no liability for any vulnerability. Customer should regularly check security updates from NXP and follow up appropriately.

Customer shall select products with security features that best meet rules, regulations, and standards of the intended application and make the ultimate design decisions regarding its products and is solely responsible for compliance with all legal, regulatory, and security related requirements concerning its products, regardless of any information or support that may be provided by NXP.

NXP has a Product Security Incident Response Team (PSIRT) (reachable at PSIRT@nxp.com) that manages the investigation, reporting, and solution release to security vulnerabilities of NXP products.

NXP B.V. — NXP B.V. is not an operating company and it does not distribute or sell products.

Trademarks

Notice: All referenced brands, product names, service names, and trademarks are the property of their respective owners.

NXP — wordmark and logo are trademarks of NXP B.V.

Airfast — is a trademark of NXP B.V.

Freescale — is a trademark of NXP B.V.

Contents

1	General description	1	8.6	Engineering Mode (EM).....	13
2	Typical performance	1	9	Ordering information	13
3	Features and benefits	1	10	Component layout and parts list	14
4	Pinning information	2	10.1	Component layout	14
4.1	Pinning	2	10.2	Component designations and values	15
4.2	Functional pin description	3	11	Temperature sensor	15
5	Electrical characteristics	4	12	Communication interface	16
5.1	Ratings	4	12.1	I ² C	16
5.1.1	Limiting values	4	12.1.1	I ² C addressing	16
5.1.2	Lifetime.....	4	12.1.2	I ² C instruction set.....	17
5.1.3	ESD protection characteristics.....	4	12.1.3	I ² C Device ID Read instruction.....	18
5.1.4	Moisture sensitivity level.....	4	12.2	I ² C electrical specification and timing for I/O stages and bus lines.....	19
5.2	Operating characteristics.....	5	12.2.1	I ² C SCLK and SDA characteristics.....	20
5.2.1	Nominal DAC settings	5	12.2.2	I ² C bus electrical characteristics	21
5.2.2	Functional tests.....	5	13	Design considerations	21
5.2.3	Wideband ruggedness	6	13.1	Power on sequence.....	21
5.2.4	Typical performance.....	6	13.2	Programming guidelines to avoid hardware failure or damage	22
6	Register map and OTP memory	7	13.3	Group programming	22
6.1	One-time programmable memory	7	14	Product marking	22
6.2	Register map	7	15	Package information	23
7	Power supply sequence	11	16	Product software and tools	29
8	Autobias functionality	11	17	Failure analysis	29
8.1	General overview	11	18	Revision history	29
8.2	Operational overview.....	11		Legal information	30
8.3	Tx enable control	12			
8.4	Sense_DAC.....	13			
8.5	VGS_DAC	13			

Please be aware that important notices concerning this document and the product(s) described herein, have been included in section 'Legal information'.

© 2024 NXP B.V.

All rights reserved.

For more information, please visit: <https://www.nxp.com>

[Document feedback](#)

Date of release: 1 July 2024

Document identifier: A3M38SL039