

## NXP isolated high-speed CAN transceiver TJF1052i

# HS-CAN transceiver with integrated galvanic isolation

The TJF1052i high-speed controller area network (HS-CAN) transceiver provides a galvanically isolated interface between a CAN protocol controller and the physical two-wire HS-CAN bus. It is specifically aimed at industrial applications, where galvanic isolation is necessary to bridge CAN communication between different voltage domains.

### KEY FEATURES

- ▶ Compatible with 3 and 5 V microcontrollers
- ▶ Low electromagnetic emission (EME) and high electromagnetic immunity (EMI)
- ▶ 5 kV (RMS) rated isolation voltage, compliant with UL1577, IEC61010, and IEC60950
- ▶ Bus pins protected against transients in noisy environments
- ▶ Transmit data (TxD) dominant time-out function
- ▶ Undervoltage detection on supply pins

### APPLICATIONS

- ▶ Building automation
- ▶ Transportation equipment, including Engine control units (ECUs) operating in the high-voltage domain
- ▶ Manufacturing (sensors, drive and control systems)
- ▶ Battery management and power distribution systems
- ▶ Chargers for electrically powered vehicles

### KEY BENEFITS

- ▶ Flawless isolator and transceiver operation
  - Increased reliability due to fewer components
  - Guaranteed system performance, e.g. max loop delay < 220 ns
- ▶ Reduced board space due to integration of isolator and transceiver in one SO16WB package
- ▶ Protect electronics against overvoltage, ground offset, and reverse current
- ▶ Higher signal integrity and improved noise immunity

As a member of NXP's third-generation HS-CAN transceiver family, the TJF1052i offers significant advantages over previous devices, including better EMC and ESD performance, as well as ideal passive behavior to the CAN bus when the transceiver supply voltage is off.



## SAFETY

Designers of CAN networks in industrial and high-voltage applications know that isolation is essential for two main reasons: to protect against electric shocks and to protect electronics from damage.

NXP's TJF1052i transceiver combines this protection with outstanding performance and reliability, especially for high-speed CAN networks operating at up to 1 Mbit/s.

By integrating the galvanic isolation within the transceiver, the TJF1052i eliminates the need for standalone isolation, improves reliability, and enhances system-performance parameters such as loop delay.

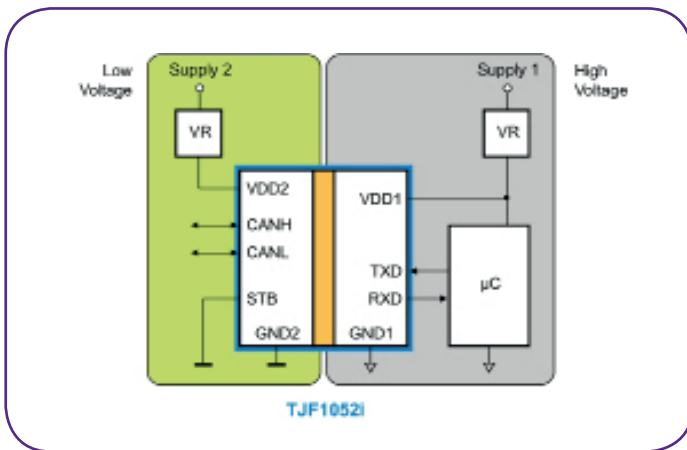

## SIGNAL INTEGRITY

The TJF1052i integrates capacitive-isolation technology to transmit and receive CAN signals through the isolation barrier. This enables more reliable data communication in extremely noisy environments, such as high-voltage battery management systems, energy distribution systems, or when driving high-power motors or invertors.

The TJF1052i is an excellent choice for all types of industrial CAN networks, especially where isolation is required for safety reasons, to break ground loops, or to enhance signal integrity in noisy environments.

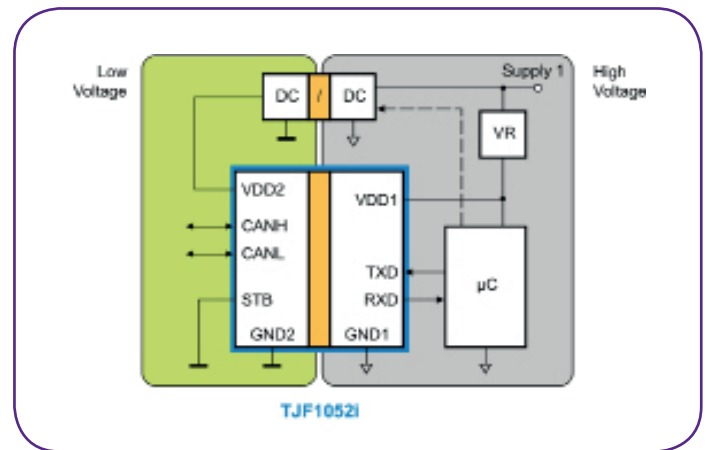

## Example application diagrams

## Quick reference data

Symbol	Parameter	Conditions	Min	Typ	Max	Unit
$V_{DD1}$	supply voltage		3.0	-	5.25	V
$V_{DD2}$	supply voltage		4.75	-	5.25	V
$V_{ESD}$	electrostatic discharge voltage	IEC 61000-4-2 at pins CANH and CANL	-8	-	8	kV
$V_{CANH/L}$	voltage on pin CANH/CANL	no time limit; DC limiting value	-58	-	58	V
$T_{vj}$	virtual junction temperature		-40	-	125	°C
$T_{amb}$	ambient temperature		-40	-	105	°C

## Ordering information

Type number	Rated voltage	Working voltage
TJF1052iT/5	5 kV (RMS)	up to 800 V (RMS)*
TJF1052iT/2	2.5 kV (RMS)	up to 450 V (RMS)*
TJF1052iT/1	1 kV (RMS)	up to 300 V (RMS)*

\* According IEC60664 Overvoltage Category II. Basic Insulation. See datasheet for full details

[www.nxp.com](http://www.nxp.com)

© 2013 NXP Semiconductors N.V.

All rights reserved. Reproduction in whole or in part is prohibited without the prior written consent of the copyright owner. The information presented in this document does not form part of any quotation or contract, is believed to be accurate and reliable and may be changed without notice. No liability will be accepted by the publisher for any consequence of its use. Publication thereof does not convey nor imply any license under patent- or other industrial or intellectual property rights.

Date of release: September 2013

Document order number: 9397 750 17460

Printed in the Netherlands