



NXP cable silicon tuner TDA18250

High-performance silicon tuner for cost-sensitive cable zapper STB

This advanced, single-package solution reduces size and cost by integrating all the functions for receiving an RF channel in the cable TV band from 42 to 862 MHz.

Key features

- ▶ RF input with direct cable connection
- ▶ Low IF output, connecting directly to demodulators
- ▶ RF loop-through
- ▶ Frequency coverage: 42 to 862 MHz
- ▶ High sensitivity and high power robustness
- ▶ Multistandard cable reception covering i.e. NorDig and SARFT standards
- ▶ Suppression of third and fifth signal harmonics
- ▶ Optimum adjacent channel rejection
- ▶ Single 3.3 V supply with low power consumption
- ▶ High accuracy Received Signal Strength Indicator (RSSI)

Applications

- ▶ Single-tuner cable STBs
- ▶ Very small cable tuner modules

The NXP TDA18250 supports the trend of replacing can tuners with silicon tuners to create cost-competitive set-top boxes (STBs). High integration reduces the size and cost of the application.

Designed for use in the cable TV band from 42 to 862 MHz, this single-package device builds on NXP's proven silicon tuner technology and has been designed to minimize the number and cost of external components. It offers all the features required for reception in a single-stream STB.



TDA18250 block diagram

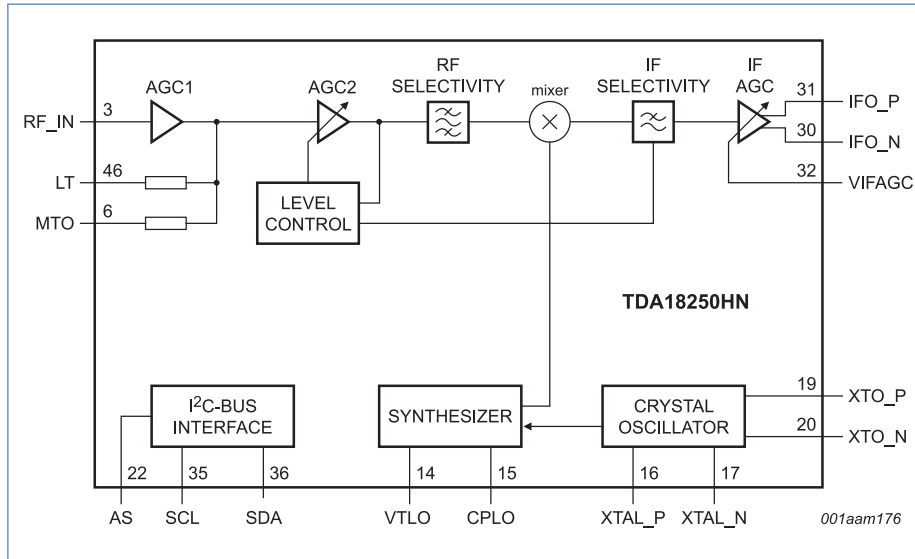

OM3914: TDA18250-based front-end with TDA10024 cable demodulator



OM3925C: TDA18250 tuner-only board for easy STB integration and validation

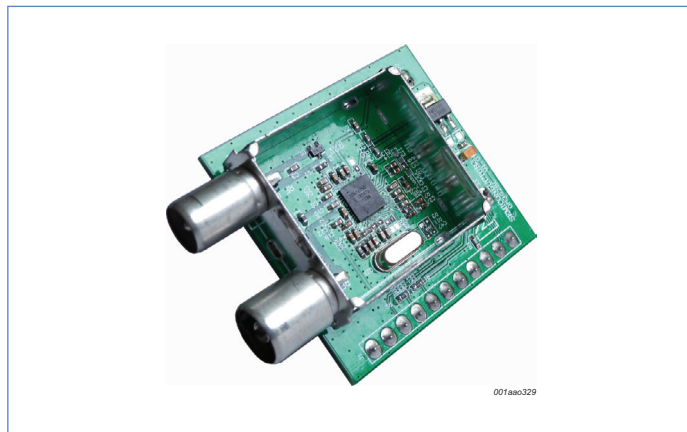

OM3948C: TDA18250 tuner in can-tuner-like enclosure for very small applications

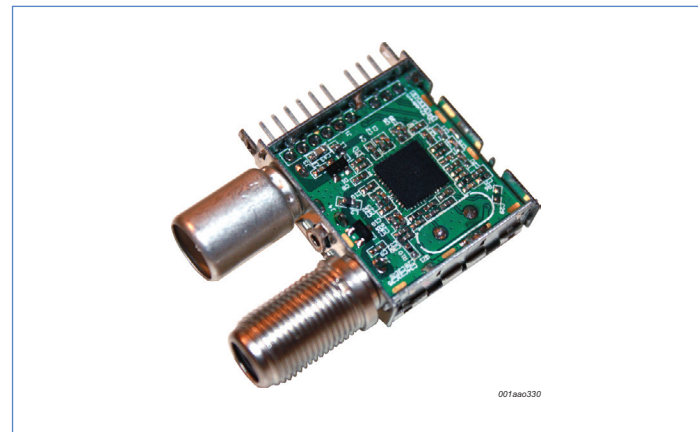

Key parameters

Parameter	Value (typical)
Sensitivity (64 QAM)	34 dB μ V
Max input level (64 QAM)	110 dB μ V
Input return loss	-8 dB
CSO	-60 dB
CTB	-60 dB
IF selectivity	6/7/8/9 MHz 5 th order LPF 0.4/0.85/1/1.5 MHz 2 nd order HPF
AGC	Free
NF	5.5 dB
RSSI accuracy (absolute)	\pm 3 dB
RSSI accuracy (relative)	\pm 0.5 dB
Power consumption	\sim 850 mW

www.nxp.com

© 2011 NXP Semiconductors N.V.

All rights reserved. Reproduction in whole or in part is prohibited without the prior written consent of the copyright owner. The information presented in this document does not form part of any quotation or contract, is believed to be accurate and reliable and may be changed without notice. No liability will be accepted by the publisher for any consequence of its use. Publication thereof does not convey nor imply any license under patent- or other industrial or intellectual property rights.

Date of release: July 2011

Document order number: 9397 750 17142

Printed in the Netherlands