

A Single-Phase Energy Meter with Capacitive Power Supply and Shunts

by: **Neeraj Mangla**
Microcontroller Solutions Group
Noida
India

1 Introduction

The MC9S08GW64 is a low-power MCU suitable for a single-phase energy metering application. It is capable of running on a capacitive power supply. A shunt can be used for the current-sensing element. This use of a capacitive power supply and a shunt for current sensing make the MC9S08GW64 suitable for a very low-cost bill of material (BOM) energy meter.

The first half of this application note describes the use of the capacitive supply for a single-phase energy metering application. A detailed analysis of the power requirements of the MC9S08GW64 is included. Sample software application code has also been provided, to be directly used in an application. The second half of this document describes how to connect the voltage and current sensing circuit to the MC9S08GW64. Schematics for the voltage sensing circuit and the current sensing circuit have also been provided.

2 Energy meter power supply

An MC9S08GW64-based energy meter requires a 2.1–3.3 V DC power supply to perform its operation. This DC voltage source can be generated in several ways.

Traditionally the DC supply is generated using the transformers, rectifier, and switching elements such as a MOSFET/inductor. However, a transformer/switch-based power supply might not be an effective solution for low-power, low-cost embedded systems. A transformer occupies a considerable amount of space

Contents

1	Introduction.....	1
2	Energy meter power supply.....	1
2.1	Capacitive power supply.....	2
3	Current requirements.....	3
3.1	Software for different clock configuration.....	3
4	ADC connection with voltage and current.....	4
5	Voltage sensing circuit.....	4
6	Current-sensing circuit.....	4
6.1	Using a shunt for current sensing.....	5
6.2	Using a current transformer for current sensing.....	5
7	Voltage level shifter circuit.....	6

energy meter power supply

and weight on the PCB when compared with the size of the integrated solution we offer here. A transformer on a printed circuit board (PCB) adds noise into the system. Energy meters are very sensitive to this noise, which affects their accuracy. For switching supplies, the biggest drawback is cost. The cost of the power supply is quite high when compared with the actual cost of the full system.

Therefore the power supply solutions discussed above are not the preferred solution for low-power and low-cost embedded systems. These low-power and low-cost challenges are well addressed by capacitive/resistive supplies. In the following section we will discuss the capacitive power supply.

2.1 Capacitive power supply

A capacitive power supply is the best solution for a low-cost energy meter. It works on the principle of reducing the line voltage by having a series capacitor between phase and neutral. Current flowing through this capacitor is inversely proportional to the impedance of the capacitor as given by the formula:

$$\text{Impedance}(Z) = 1/2\pi fc$$

where

f is the line frequency and

c is the capacitance of the series capacitor.

The output of the capacitor needs to be rectified to generate the DC output signal. The conversion from AC to DC is done using a rectifier — either half-wave or full-wave. In Figure 1 D2 is used for half-wave rectification. This passes the positive half-cycle of the current and charges the bulk capacitor C2. During the negative-half cycle, the current is bypassed through the zener diode D1. Current flowing through this zener diode must be controlled by resistance so that it operates within the maximum current limit. R1 is used to control the current flowing through the zener diode.

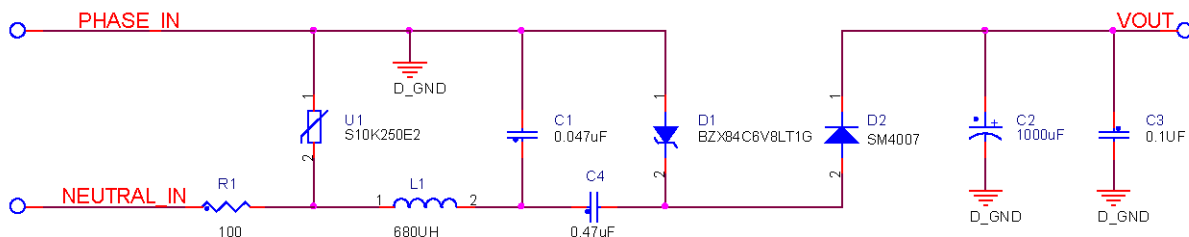

Figure 1. Schematic of capacitor-based power supply

The output current of the rectifier circuit has ripples of positive half-cycles, so a bulk capacitor C2 is used to provide a ripple-free DC signal to the system. This capacitor provides smooth output voltage until the amount of load current is less than the charging current.

If the required load current exceeds the charging current, then C2 will have a sawtooth output. To obtain a higher output current, increase the capacitor value C4 on the AC line.

A filter network consisting of C1 and L1 removes noise from the input AC signal.

Table 1 shows the typical current values produced by different values of series capacitors.

Table 1. Maximum MCU average current values for a 220 V / 50 Hz supply

AC capacitor maximum value	MCU average current value
220 nF	4.9 mA
330 nF	7.3 mA

AC capacitor maximum value	MCU average current value
470 nF	10.4 mA
680 nF	15 mA
1 μF	22.1 mA

The advantages of this solution are:

- The transformer is removed and cost is significantly reduced.
- The power supply size is smaller.
- Maximum output current values are proportional to the AC capacitor values.

Removing the transformer optimizes the cost and weight. However, the user needs to take care while connecting another system to the energy meter because the capacitive power supply is not isolated from the AC line voltage and the microcontroller is powered directly from the AC line. Opto-couplers are recommended for external communication ports.

3 Current requirements

The MC9S08GW64 is a low-power MCU, with a current consumption of less than 1 mA/MHz. Below is the current consumption data of the MC9S08GW64 at different frequencies. Refer to the MC9S08GW64 data sheet for information on current consumption.

Table 2. MC9S08GW64 current consumption

Symbol	Parameter	Conditions	Value ¹	Unit
R _{IDD}	Run supply current FEI mode, all modules on	20 MHz	17.088	mA
		8 MHz	7.543	
		4 MHz	4.25	
		2 MHz	2.518	

1. Values specified at 25 °C

3.1 Software for different clock configuration

The MC9S08GW64 is capable of running at speeds of up to 20 Mhz. There are three possible clock sources to the FLL for generating the system clock:

- Internal RC oscillator
- External oscillator 1
- External oscillator 2

One of these three sources is input as a low frequency clock to the FLL. The FLL generates the high frequency system clock by multiplying this input clock to generate the system clock. Here is the clock configuration for the MC9S08GW64:

```
// Code to generate the 20 Mhz clock using the internal RC oscillator.
ICSC1 = 0x06;
ICSC2 = 0x00;
ICSTRM = *(unsigned char *)0xFFAF;
ICSSC = 0x00; // 16 Mhz bus clock for 20 Mhz put it 0x20
```

4 ADC connection with voltage and current

The MC9S08GW64 has two dedicated ADCs. One ADC is used for sensing the current and voltage of the phase. The other ADC is for the neutral. Refer to Freescale application note AN4168, "ADC16 Calibration Procedure and Programmable Delay Block Synchronization." Each ADC is capable of sampling the voltage and the current and then storing the resulting values in the result register. A read operation of both of these result registers can be triggered by a single interrupt event by the PDB. The voltage signal and the current signal of the phase is routed to one ADC and the current signal related to the neutral is routed to the other ADC.

These ADCs have one channel that can be configured in differential mode. It is recommended to connect the current channel in differential mode.

Phase Signal Connection

The voltage signal is attenuated and level-shifted in the signal conditioning circuit, then routed to one channel of the ADC. The current signal is amplified and level-shifted in the signal conditioning circuit, then routed to the other channel of the ADC.

Neutral Signal Connection

The current signal output from the current transformer is level-shifted and then routed to the ADC channel.

5 Voltage sensing circuit

In order to sense the 230 V signal on the ADC, this signal needs to be attenuated so that the maximum peak voltages are well within the limits of the ADC. A resistor attenuation circuit is used to attenuate the signal.

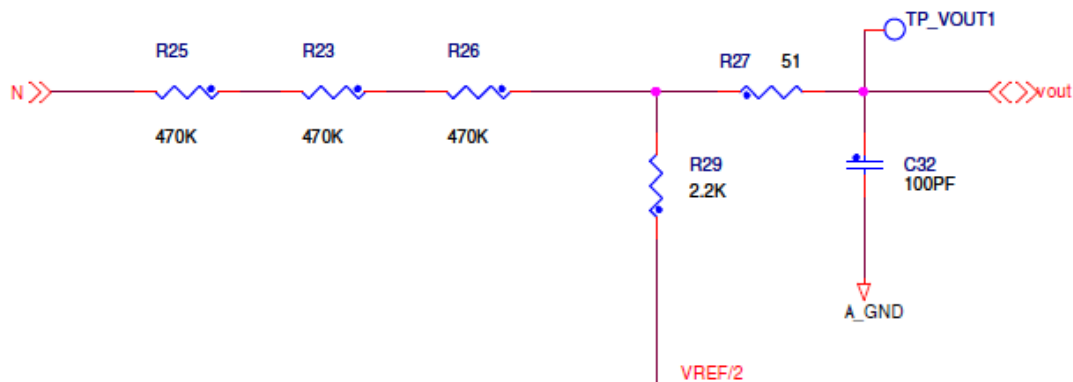

Figure 2. Voltage sensing circuit

6 Current-sensing circuit

In order for the energy meter to be more accurate over its full dynamic range, the dynamic range can be split into two parts, with each part having a different gain. Therefore two phase current signals are sampled for sensing by the ADCs. Two signals are sampled for the phase current while a third is sampled for the neutral current. A shunt-based circuit is used for the phase current sensing and a CT-based circuit is used for the neutral current. Refer to the next sections for the shunt sensor and CT sensor connection to the channels of the ADC.

6.1 Using a shunt for current sensing

A shunt is a cost-effective solution for the two-wire distribution system. A shunt has many advantages over current transformers. Shunts do not suffer from the DC saturation effect. Also, the phase response of a shunt is linear across the complete range of the input current. Because it is purely resistive, a shunt dissipates more power in the form of heat when high current is passed through it, increasing the overall power consumption of the energy meter.

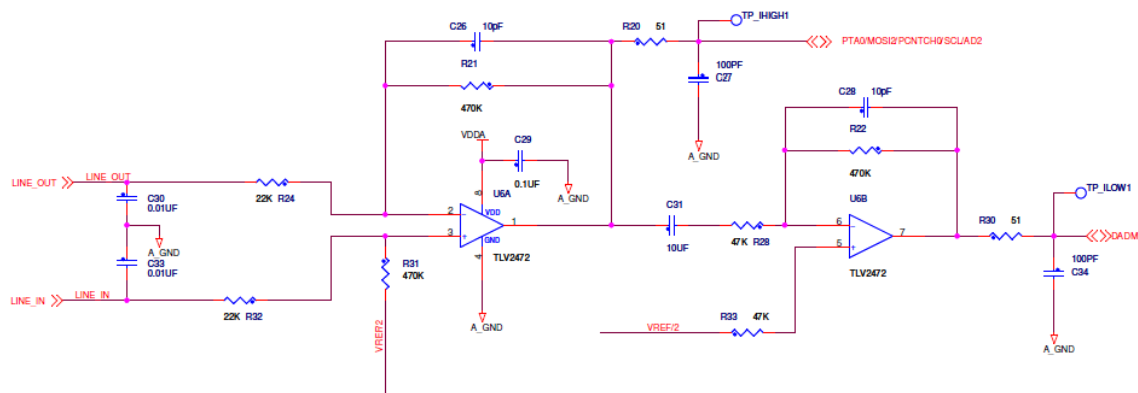

Figure 3. Circuit for current sensing by shunt

6.2 Using a current transformer for current sensing

A current transformer (CT) is used to sense the current passing through the neutral lines. The turn ratio of the CT determines the current in the secondary coil of the transformer. The turn ratio of the CT must be chosen in such a way that the CT does not get saturated over the full dynamic range of the energy meter. A load resistor is used to convert the secondary current of the CT into the voltage signal. The voltage level of this signal must remain within the limits of the MC9S08GW64's ADC.

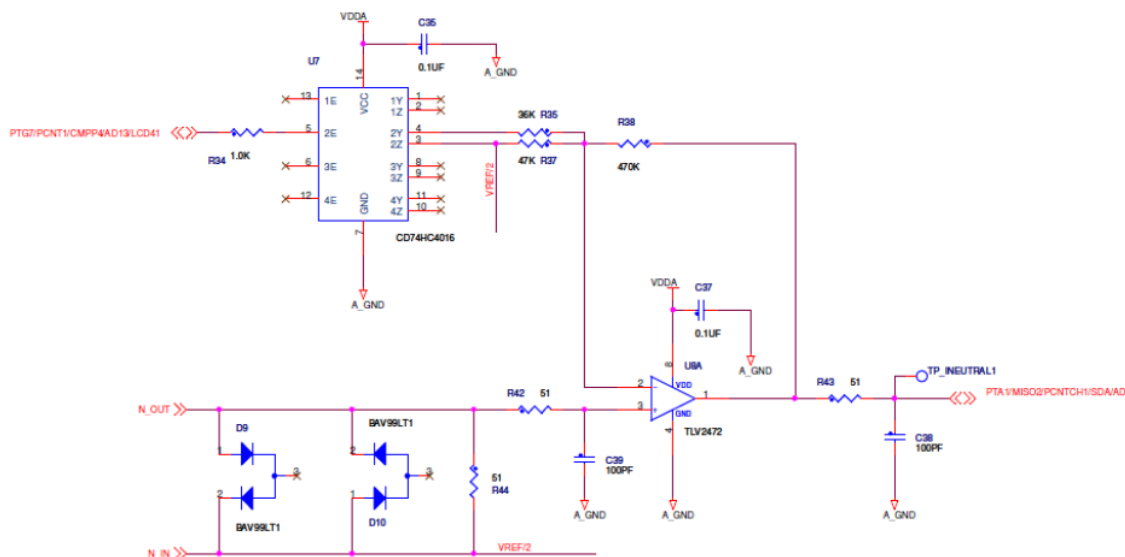

Figure 4. Circuit for current sensing by current transformer

7 Voltage level shifter circuit

The voltage and current signals must be level-shifted before being input to the ADC. The MC9S08GW64 MCU has a regulated reference voltage available. This regulated reference voltage can be used as a source of the DC bias voltage used to level shift the voltage and the current signals.

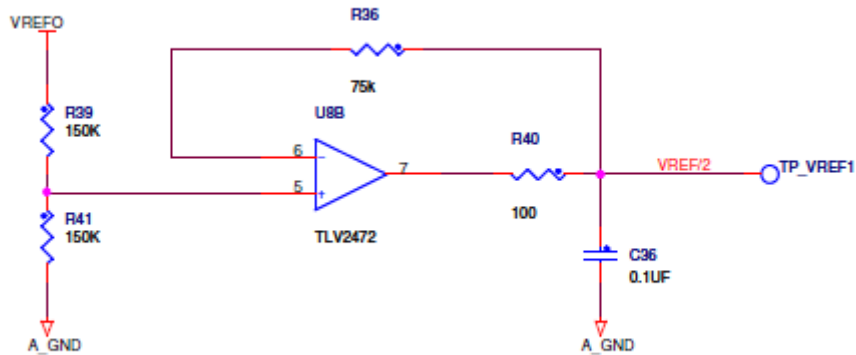

Figure 5. Circuit for voltage level shifting

How to Reach Us:

Home Page:

www.freescale.com

Web Support:

<http://www.freescale.com/support>

USA/Europe or Locations Not Listed:

Freescale Semiconductor
Technical Information Center, EL516
2100 East Elliot Road
Tempe, Arizona 85284
+1-800-521-6274 or +1-480-768-2130
www.freescale.com/support

Europe, Middle East, and Africa:

Freescale Halbleiter Deutschland GmbH
Technical Information Center
Schatzbogen 7
81829 Muenchen, Germany
+44 1296 380 456 (English)
+46 8 52200080 (English)
+49 89 92103 559 (German)
+33 1 69 35 48 48 (French)
www.freescale.com/support

Japan:

Freescale Semiconductor Japan Ltd.
Headquarters
ARCO Tower 15F
1-8-1, Shimo-Meguro, Meguro-ku,
Tokyo 153-0064
Japan
0120 191014 or +81 3 5437 9125
support.japan@freescale.com

Asia/Pacific:

Freescale Semiconductor China Ltd.
Exchange Building 23F
No. 118 Jianguo Road
Chaoyang District
Beijing 100022
China
+86 10 5879 8000
support.asia@freescale.com

For Literature Requests Only:

Freescale Semiconductor Literature Distribution Center
1-800-441-2447 or +1-303-675-2140
Fax: +1-303-675-2150
LDCForFreescaleSemiconductor@hibbertgroup.com

Information in this document is provided solely to enable system and software implementers to use Freescale Semiconductors products. There are no express or implied copyright licenses granted hereunder to design or fabricate any integrated circuits or integrated circuits based on the information in this document.

Freescale Semiconductor reserves the right to make changes without further notice to any products herein. Freescale Semiconductor makes no warranty, representation, or guarantee regarding the suitability of its products for any particular purpose, nor does Freescale Semiconductor assume any liability arising out of the application or use of any product or circuit, and specifically disclaims any liability, including without limitation consequential or incidental damages. "Typical" parameters that may be provided in Freescale Semiconductor data sheets and/or specifications can and do vary in different applications and actual performance may vary over time. All operating parameters, including "Typicals", must be validated for each customer application by customer's technical experts. Freescale Semiconductor does not convey any license under its patent rights nor the rights of others. Freescale Semiconductor products are not designed, intended, or authorized for use as components in systems intended for surgical implant into the body, or other applications intended to support or sustain life, or for any other application in which failure of the Freescale Semiconductor product could create a situation where personal injury or death may occur. Should Buyer purchase or use Freescale Semiconductor products for any such unintended or unauthorized application, Buyer shall indemnify Freescale Semiconductor and its officers, employees, subsidiaries, affiliates, and distributors harmless against all claims, costs, damages, and expenses, and reasonable attorney fees arising out of, directly or indirectly, any claim of personal injury or death associated with such unintended or unauthorized use, even if such claims alleges that Freescale Semiconductor was negligent regarding the design or manufacture of the part.

RoHS-compliant and/or Pb-free versions of Freescale products have the functionality and electrical characteristics as their non-RoHS-complaint and/or non-Pb-free counterparts. For further information, see <http://www.freescale.com> or contact your Freescale sales representative.

For information on Freescale's Environmental Products program, go to <http://www.freescale.com/epp>.

Freescale™ and the Freescale logo are trademarks of Freescale Semiconductor, Inc. All other product or service names are the property of their respective owners.

© 2010 Freescale Semiconductor, Inc.