

# AN13415

## PCA9481A monolithic integrated high-voltage 2:1 switched capacitor direct battery charger

Rev. 2.3 — 20 November 2023

Application note

### Document information

Information	Content
Keywords	PCA9481A 10A 2:1/1:2/1:1 mode switched capacitor
Abstract	This application note describes the details of customer applications including external components.



# 1 Abstract

Many mobile phones have adopted features requiring high system performance such as 5G, multiple cameras and high resolution LCDs with multi-processors, increasing the demand for higher battery capacity. These power-hungry features have created the need for users to charge their mobile phone batteries frequently and quickly.

Legacy inductor-based chargers are still widely used in mobile applications, but the high heat from induction charging limits higher charging power for the battery, unable to satisfy users requiring fast charging.

Switched-capacitor (SC) direct charging has been recognized as a good replacement of inductor-based chargers due to higher efficiency with lower heat dissipation. Fast direct chargers have become mandatory in many mobile phones including low-tier models.

PCA9481A achieves best-in-class SC direct charging in terms of efficiency with lower BOMs.

This application note describes the details of customer applications including external components.

# 2 PCA9481A charging application

## 2.1 50 W charging application at $IVBUS \leq 3 A$

Mobile device integrates USB Type-C receptacle basically, but most Type-C cables only support up to 3 A current delivery and E-mark chip should be mounted onto Type-C cable for greater than 3 A current. To achieve 50 W charging with exiting cable not mounted to an E-mark chip, higher input voltage is required. [Figure 1](#) provides the proper solution to charge a battery with a 3 A Type-C USB cable.

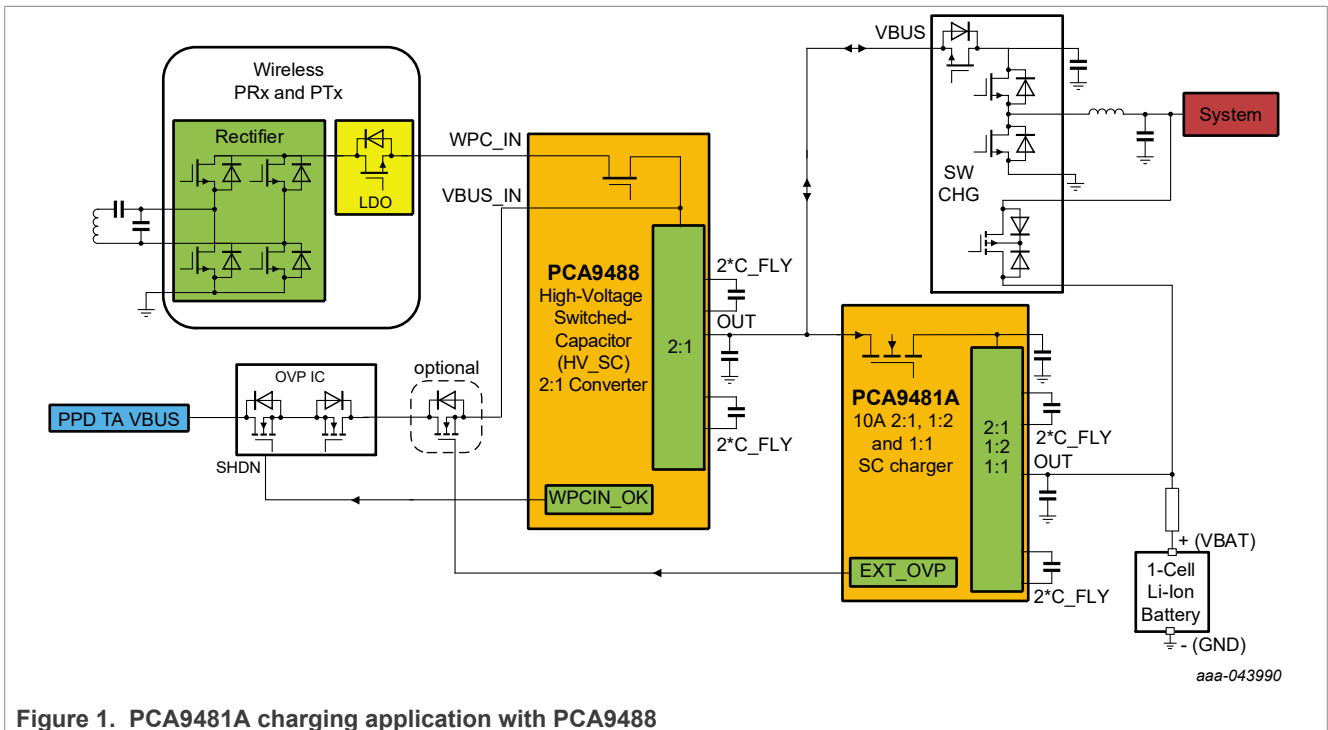

Figure 1. PCA9481A charging application with PCA9488

For 50 W charging with under 3 A input current, input voltage of 2 x 2:1 cascade SC converters should be 4 times higher than output voltage to achieve max 10 A output current. We recommend to use PCA9488 just before PCA9481A for half of the input current with a single SC 2:1 charger.

PCA9481A monolithic integrated high-voltage 2:1 switched capacitor direct battery charger

PCA9481A is placed in parallel with an inductor-based switching charger that is operated during USB PD; controller cannot adjust input voltage and current according to battery condition, such as fully discharged battery. In this case, mobile AP can't be started up to implement USB PD.

Output voltage of PCA9488 is 0.5x input voltage and output current is 2x input current. So VBUS should be 4x output voltage of PCA9481A, and current at VBUS is ¼ of output current of PCA9481A.

Optionally external FET between OVP and VBUS\_IN of PCA9488 could be the replacement of OVP IC depending on application requirement. NMOS and back-to-back can be selected.

2.2 50 W charging application without additional 2:1 converter

Input current of VBUS reaches 5 A which is half of max output current. Single PCA9481A can support 50 W charging without additional SC converter.

An example of the charging block is shown in [Figure 2](#)

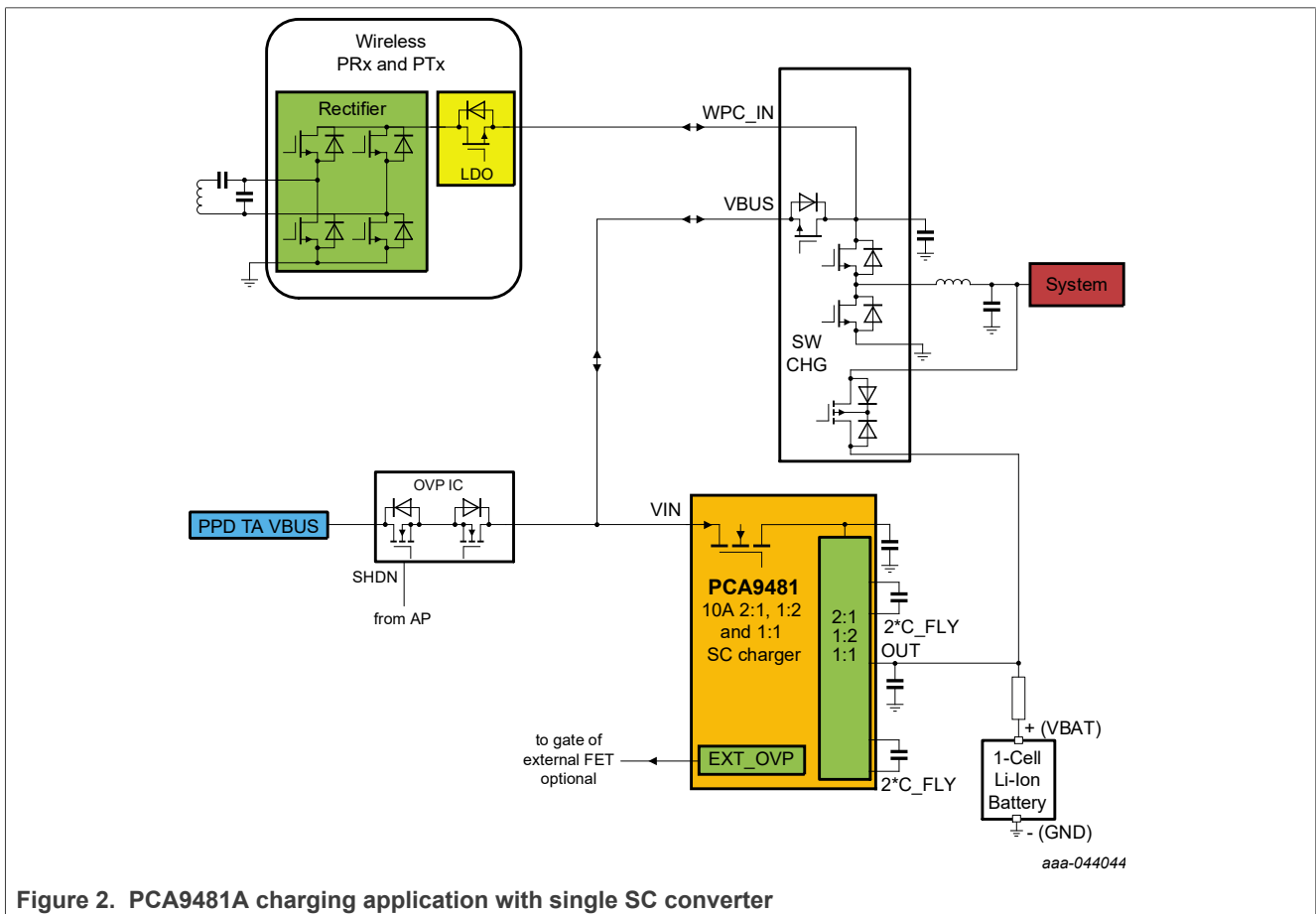

### 3 PCA9481A reference schematic

#### 3.1 Reference schematic with external FET controlled by PCA9481A

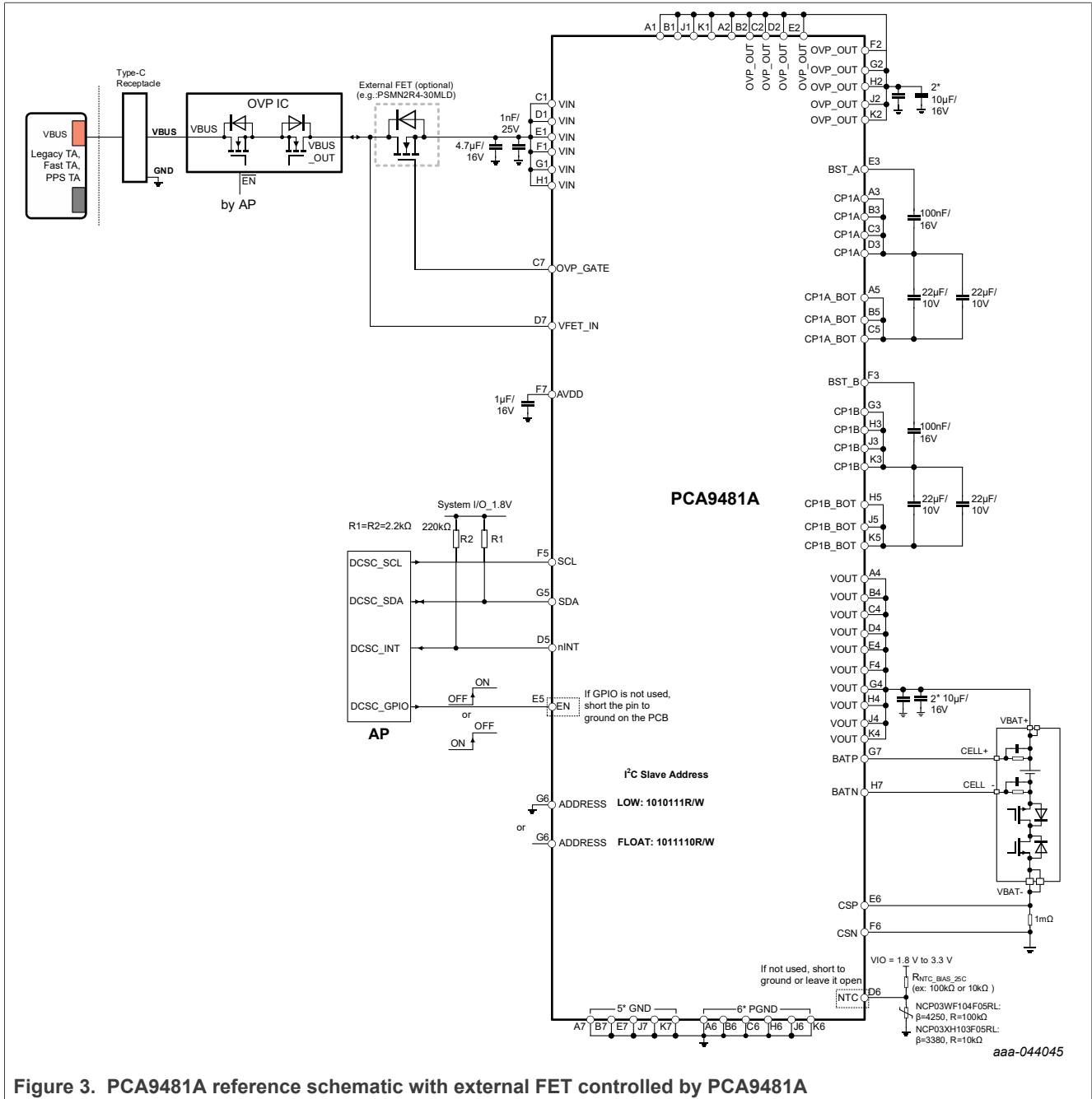

Figure 3. PCA9481A reference schematic with external FET controlled by PCA9481A

### 3.2 Reference schematic with OVP IC

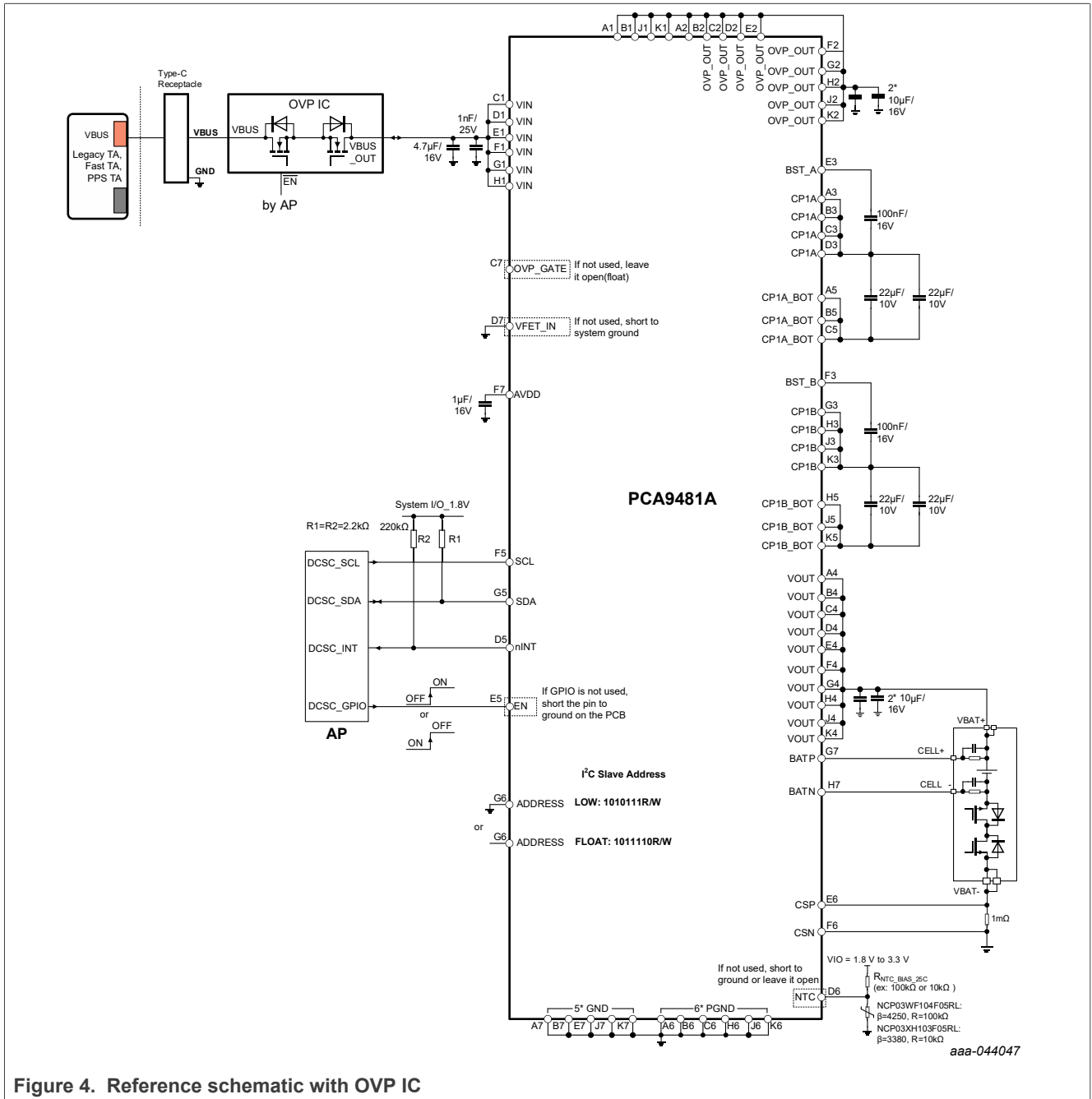

Figure 4. Reference schematic with OVP IC

### 3.3 I<sup>2</sup>C and other digital pins

PCA9481A provides the option of two I<sup>2</sup>C slave addresses determined by the ADDRESS pin setting as shown in [Table 1](#).

Table 1. I<sup>2</sup>C slave addresses

ADDRESS	Slave Address (Write) in hex	Slave Address (Read) In hex
LOW	AE	AF
FLOAT	BC	BD

I<sup>2</sup>C clock speed supports up to 1 MHz. SDA and SCL require a 2.2 kΩ pullup resistor.

EN pin is the digital pin to enabling device. The polarity of EN pin is selected in EN\_CFG in Register 0x18.

nINT is the open drain output requiring a 220 kΩ pullup resistor. It goes LOW when any unmasked interrupt bit is asserted.

nINT pin can be floating or open if not used.

### 3.4 NTC

The NTC input with AVDD pull-up voltage is connected to an external negative temperature coefficient (NTC) thermistor to monitor system temperature or NTC on battery package to monitor battery temperature. To utilize NTC function, set NTC\_EN bit to 1b. There are two registers to set a different temperature threshold such as hot/warm and cold/cool. If one of two programmed threshold is monitored, the device issues a corresponding interrupt signal.

### 3.5 AVDD

AVDD is the internal LDO output requiring a 1 μF/6.3 V bypass capacitor. Typical AVDD is 1.536 V. Minimum and maximum AVDD are 1.53 V and 1.54 V, respectively.

### 3.6 Input capacitor selection

In a switched capacitor converter application, large AC currents flow through the input/output capacitors. The input capacitor helps to keep the input voltage stable during switching operation.

A capacitor should be considered to flow the RMS current. Low ESR ceramic capacitors are highly recommended for this application. Larger size X7R MLCC capacitors are normally recommended. Capacitance derating needs to be considered at a DC bias voltage.

### 3.7 Flying capacitor selection

Large AC currents flow through the flying capacitors. Low ESR ceramic capacitors are highly recommended for this application. The flying capacitor must be selected to accommodate the maximum load current. Larger size X7R MLCC capacitors are normally recommended. Capacitance derating needs to be considered at a DC bias voltage.

In general, a recommended voltage ripple at C<sub>FLY</sub> is about 2 % of output voltage. If the max output voltage is 5 V, the ripple at C<sub>FLY</sub> is 100 mV. The value of C<sub>FLY</sub> can be obtained from the formula below in dual phase.

$$C_{FLY} (\mu F) = \frac{I_{OUT} (max)}{2 \times frequency \times \Delta V_{CFLY} (Voltage\ ripple)}$$

Where:

I<sub>OUT</sub> (max): A maximum output current

ΔV<sub>CFLY</sub>: voltage ripple on fly cap

Frequency: SC's operating frequency

PCA9481A monolithic integrated high-voltage 2:1 switched capacitor direct battery charger

2 x 22 μF is fully verified in application, and can support 50 W charging in smartphone form factor without additional thermal dissipation measure.

3.8 Output capacitor selection

Large AC current flows through the flying capacitors and input/output capacitors. The average output current is given by the formula below.

$$I_{OUT} = 2 \times \text{Frequency} \times C_{FLY} \times \Delta V_{CFLY}$$

The total output voltage ripple is:

$$\Delta V_{OUT} = \frac{I_{OUT}}{2 \times \text{frequency} \times (C_{FLY} + C_{SC\_OUT})}$$

A voltage ripple at C<sub>VOUT</sub> should be determined by system requirement.

3.9 Bill of Materials (BOM)

Table 2 shows all of the components for the device.

Table 2. Bill of materials

Name	Value	Size	Part name / Maker	Note
C <sub>VIN</sub>	4.7 μF/16 V	1608	Murata, GRM188C71C475ME21	C <sub>EFF</sub> =1.4 μF at 10 V
	1 nF/25 V	0603	Murata, GRM033R61E102KA01	Optional for high frequency filter
C <sub>OVP_OUT</sub>	10 μF/16 V	1608	Murata, GRM188R61C106KAAL	Two capacitors. C <sub>EFF</sub> =1.7 μF for one capacitor at 10 V
C <sub>FLY</sub>	22 μF/16 V	1608	SEMCO, CL10A226MO7JZNC	Two capacitors. C <sub>EFF</sub> = 6.9 μF at 5 V
C <sub>BST</sub>	100 nF/16 V	0603	Murata, GRM033R61C104KE14	
C <sub>VOUT</sub>	22 μF/10 V	1608	SEMCO, CL10A226MP8NUNE	Two capacitors. C <sub>EFF</sub> = 5 μF at 4.5 V
C <sub>AVDD</sub>	1 uF/6.3 V	0603	Murata, GRM033D70J105ME01	C <sub>EFF</sub> = 0.88 μF at 1.5 V
R <sub>SENSE</sub>	1/2/5 mΩ			For battery current
R <sub>I2C</sub>	2.2 kΩ	0603		SCL and SDA
R <sub>nINT</sub>	220 kΩ	0603		
NTC	β=4250 or β=3380	0603	NCP03WF104F05RL or NCP03XH103F05RL	Place it if needed
External N-ch FET	30 V, 2.4 mΩ	2.225 x 0.19 x 0.85	PSMN2R4-30MLD / Nexperia	External N-FET in case of no stand-alone OVP IC used. The N-FET is not subject to the use of this N-FET. Another N_FET or back-to-back can be used.

4 Layout guides

The device has a dual phase converter with two flying capacitors on each phase. Here is a PCB layout priority list for proper layout. Layout PCB according to this specific order is essential.

1. Utilize 8-layer board for optimal layout, and assign one layer as solid ground plane near the device to minimize high-current path
2. Place flying capacitors as close to CP1A, CP1B, CP1A\_BOT and CP1B\_BOT bumps as possible. The trace shall be wide enough to carry the charging and discharging current and short to minimize trace resistance which affects efficiency directly.

PCA9481A monolithic integrated high-voltage 2:1 switched capacitor direct battery charger

3. Place output capacitor as close as possible to VOUT bumps. Use as wide as possible on the 3<sup>rd</sup> layer to short VOUT from each phase
4. Place input capacitors as close as possible to VIN; input power trace should be routed to center of VIN pins
5. Place two OVP\_OUT capacitors next to device symmetrically
6. Decoupling capacitors shall be placed next to the device and make trace connection as short as possible
7. Ensure that there are sufficient thermal vias directly under bumps of the power FETs, power ground, connecting to copper on other layers

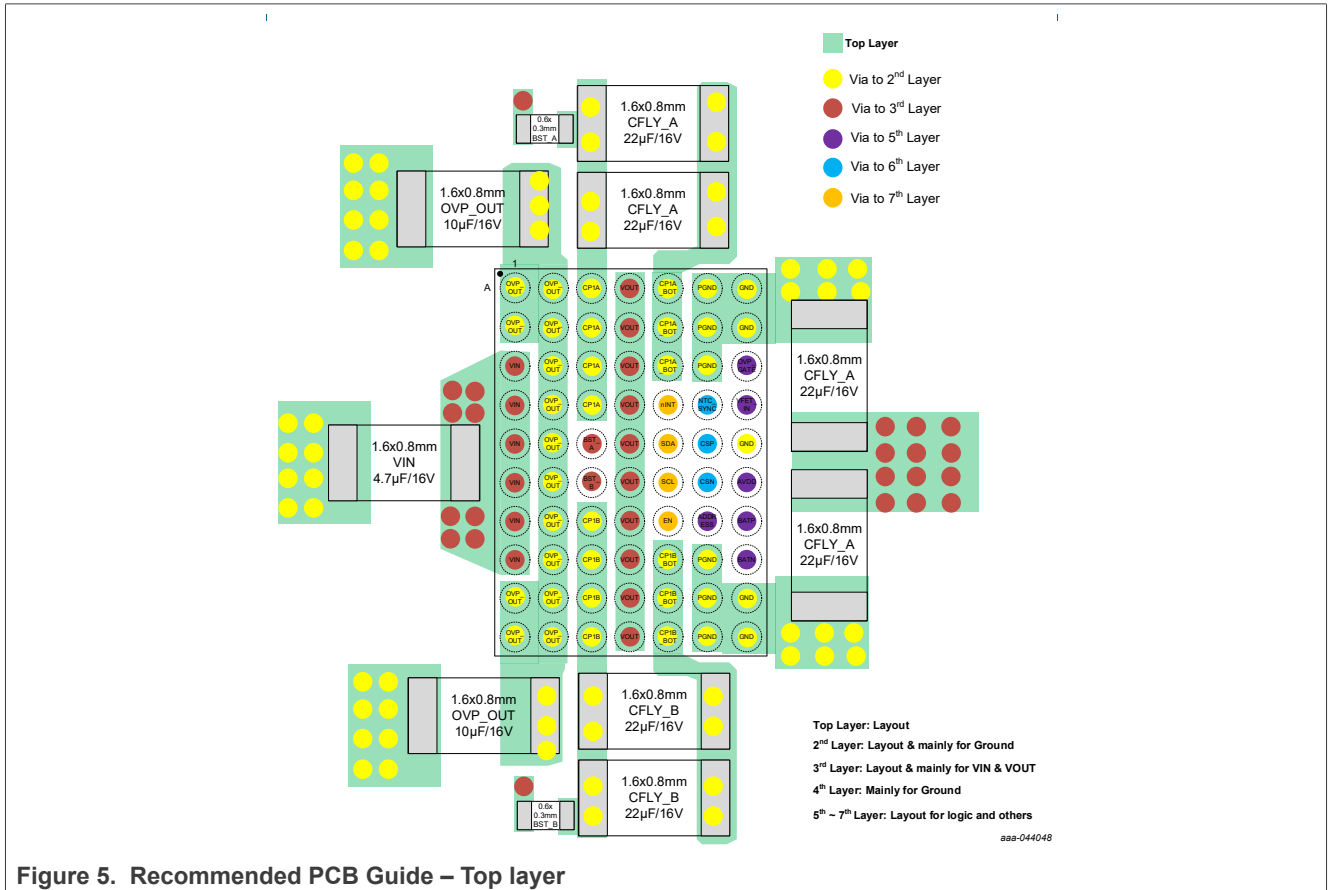

Figure 5. Recommended PCB Guide – Top layer



PCA9481A monolithic integrated high-voltage 2:1 switched capacitor direct battery charger

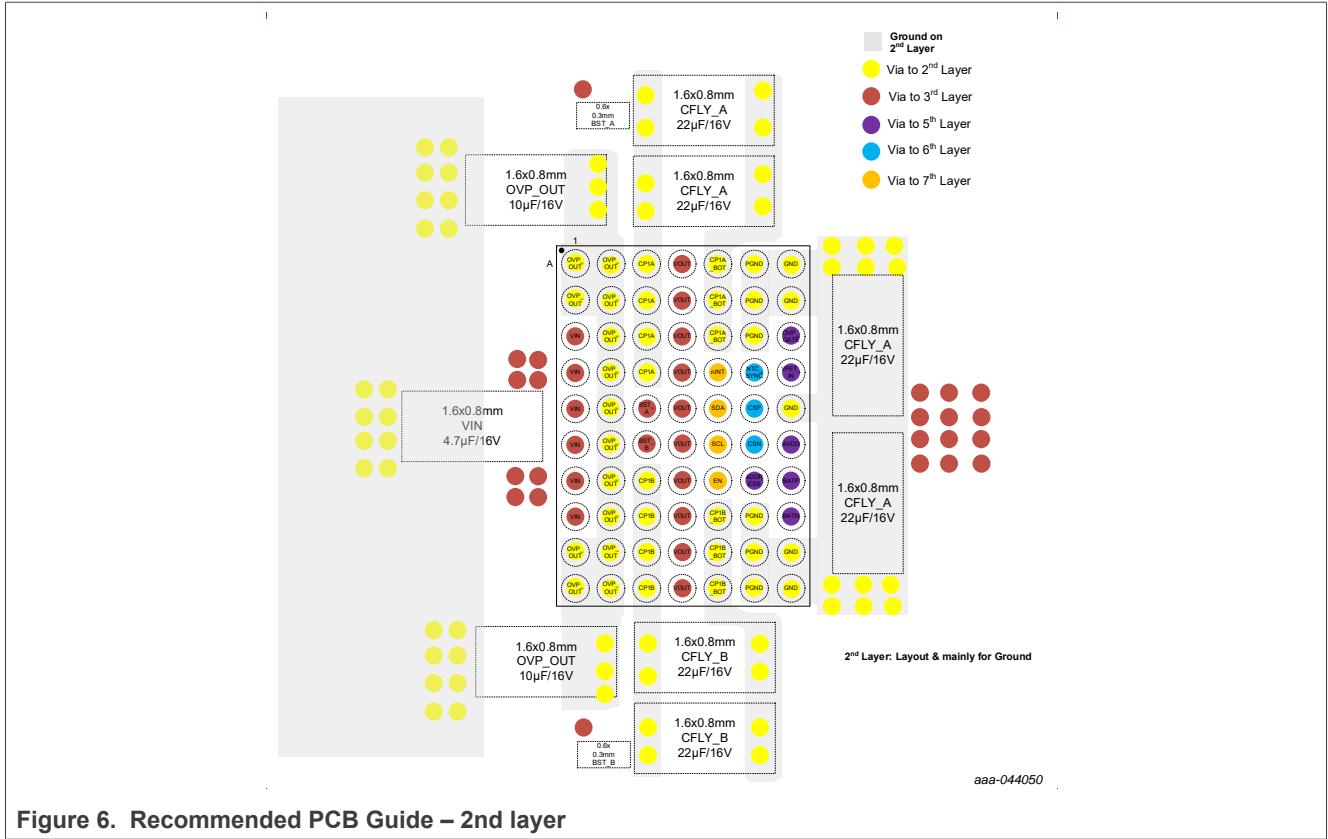

Figure 6. Recommended PCB Guide – 2nd layer

PCA9481A monolithic integrated high-voltage 2:1 switched capacitor direct battery charger

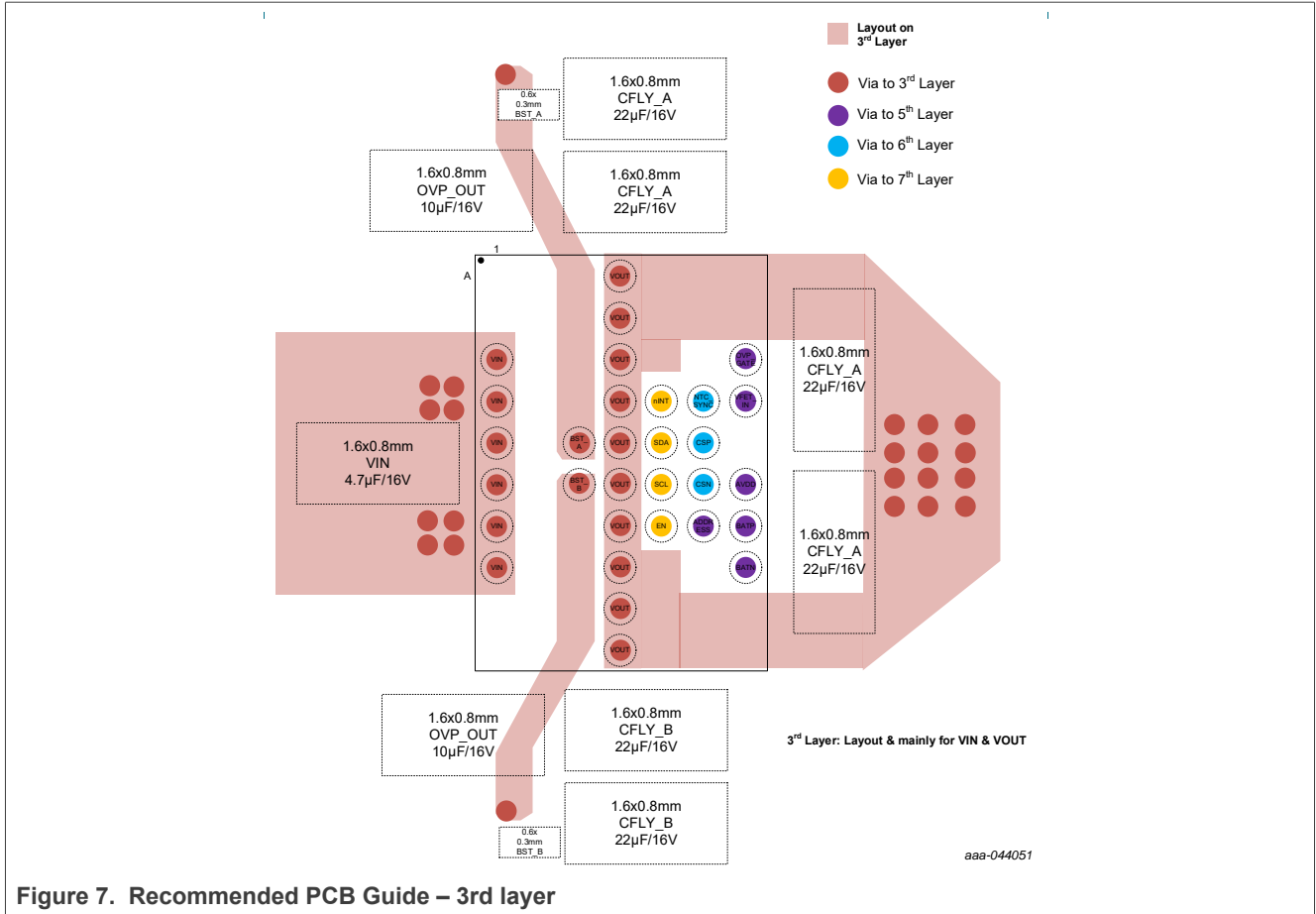

Figure 7. Recommended PCB Guide – 3rd layer

Revision history

Rev	Date	Description
v.2.3	20231120	<a href="#">Section 2.1</a> : "Output voltage of PCA9488 is 1.5x input voltage" corrected to "Output voltage of PCA9488 is 0.5x input voltage"; <a href="#">Section 5</a> moved to back of document to comply with NXPs document content standard
v.2.2	20230804	<a href="#">Section 3.5</a> : Added comment on min/max AVDD voltage
v.2.1	20230227	<a href="#">Section 3.3</a> : Added "nINT pin can be floating or open if not used."
v.2	20220718	Changed part number from PCA9481 to PCA9481A
v.1	20211020	Initial version

## Legal information

### Definitions

**Draft** — A draft status on a document indicates that the content is still under internal review and subject to formal approval, which may result in modifications or additions. NXP Semiconductors does not give any representations or warranties as to the accuracy or completeness of information included in a draft version of a document and shall have no liability for the consequences of use of such information.

### Disclaimers

**Limited warranty and liability** — Information in this document is believed to be accurate and reliable. However, NXP Semiconductors does not give any representations or warranties, expressed or implied, as to the accuracy or completeness of such information and shall have no liability for the consequences of use of such information. NXP Semiconductors takes no responsibility for the content in this document if provided by an information source outside of NXP Semiconductors.

In no event shall NXP Semiconductors be liable for any indirect, incidental, punitive, special or consequential damages (including - without limitation - lost profits, lost savings, business interruption, costs related to the removal or replacement of any products or rework charges) whether or not such damages are based on tort (including negligence), warranty, breach of contract or any other legal theory.

Notwithstanding any damages that customer might incur for any reason whatsoever, NXP Semiconductors' aggregate and cumulative liability towards customer for the products described herein shall be limited in accordance with the Terms and conditions of commercial sale of NXP Semiconductors.

**Right to make changes** — NXP Semiconductors reserves the right to make changes to information published in this document, including without limitation specifications and product descriptions, at any time and without notice. This document supersedes and replaces all information supplied prior to the publication hereof.

**Suitability for use** — NXP Semiconductors products are not designed, authorized or warranted to be suitable for use in life support, life-critical or safety-critical systems or equipment, nor in applications where failure or malfunction of an NXP Semiconductors product can reasonably be expected to result in personal injury, death or severe property or environmental damage. NXP Semiconductors and its suppliers accept no liability for inclusion and/or use of NXP Semiconductors products in such equipment or applications and therefore such inclusion and/or use is at the customer's own risk.

**Applications** — Applications that are described herein for any of these products are for illustrative purposes only. NXP Semiconductors makes no representation or warranty that such applications will be suitable for the specified use without further testing or modification.

Customers are responsible for the design and operation of their applications and products using NXP Semiconductors products, and NXP Semiconductors accepts no liability for any assistance with applications or customer product design. It is customer's sole responsibility to determine whether the NXP Semiconductors product is suitable and fit for the customer's applications and products planned, as well as for the planned application and use of customer's third party customer(s). Customers should provide appropriate design and operating safeguards to minimize the risks associated with their applications and products.

NXP Semiconductors does not accept any liability related to any default, damage, costs or problem which is based on any weakness or default in the customer's applications or products, or the application or use by customer's third party customer(s). Customer is responsible for doing all necessary testing for the customer's applications and products using NXP Semiconductors products in order to avoid a default of the applications and the products or of the application or use by customer's third party customer(s). NXP does not accept any liability in this respect.

**Terms and conditions of commercial sale** — NXP Semiconductors products are sold subject to the general terms and conditions of commercial sale, as published at <https://www.nxp.com/profile/terms>, unless otherwise agreed in a valid written individual agreement. In case an individual agreement is concluded only the terms and conditions of the respective agreement shall apply. NXP Semiconductors hereby expressly objects to applying the customer's general terms and conditions with regard to the purchase of NXP Semiconductors products by customer.

**Export control** — This document as well as the item(s) described herein may be subject to export control regulations. Export might require a prior authorization from competent authorities.

**Suitability for use in non-automotive qualified products** — Unless this document expressly states that this specific NXP Semiconductors product is automotive qualified, the product is not suitable for automotive use. It is neither qualified nor tested in accordance with automotive testing or application requirements. NXP Semiconductors accepts no liability for inclusion and/or use of non-automotive qualified products in automotive equipment or applications.

In the event that customer uses the product for design-in and use in automotive applications to automotive specifications and standards, customer (a) shall use the product without NXP Semiconductors' warranty of the product for such automotive applications, use and specifications, and (b) whenever customer uses the product for automotive applications beyond NXP Semiconductors' specifications such use shall be solely at customer's own risk, and (c) customer fully indemnifies NXP Semiconductors for any liability, damages or failed product claims resulting from customer design and use of the product for automotive applications beyond NXP Semiconductors' standard warranty and NXP Semiconductors' product specifications.

**Translations** — A non-English (translated) version of a document, including the legal information in that document, is for reference only. The English version shall prevail in case of any discrepancy between the translated and English versions.

**Security** — Customer understands that all NXP products may be subject to unidentified vulnerabilities or may support established security standards or specifications with known limitations. Customer is responsible for the design and operation of its applications and products throughout their lifecycles to reduce the effect of these vulnerabilities on customer's applications and products. Customer's responsibility also extends to other open and/or proprietary technologies supported by NXP products for use in customer's applications. NXP accepts no liability for any vulnerability. Customer should regularly check security updates from NXP and follow up appropriately. Customer shall select products with security features that best meet rules, regulations, and standards of the intended application and make the ultimate design decisions regarding its products and is solely responsible for compliance with all legal, regulatory, and security related requirements concerning its products, regardless of any information or support that may be provided by NXP.

NXP has a Product Security Incident Response Team (PSIRT) (reachable at [PSIRT@nxp.com](mailto:PSIRT@nxp.com)) that manages the investigation, reporting, and solution release to security vulnerabilities of NXP products.

**NXP B.V.** — NXP B.V. is not an operating company and it does not distribute or sell products.

### Trademarks

Notice: All referenced brands, product names, service names, and trademarks are the property of their respective owners.

**NXP** — wordmark and logo are trademarks of NXP B.V.

**Tables**

Tab. 1.	I2C slave addresses .....	6	Tab. 2.	Bill of materials .....	7
---------	---------------------------	---	---------	-------------------------	---

**Figures**

Fig. 1.	PCA9481A charging application with PCA9488 .....	2	Fig. 4.	Reference schematic with OVP IC .....	5
Fig. 2.	PCA9481A charging application with single SC converter .....	3	Fig. 5.	Recommended PCB Guide – Top layer .....	8
Fig. 3.	PCA9481A reference schematic with external FET controlled by PCA9481A .....	4	Fig. 6.	Recommended PCB Guide – 2nd layer .....	9
			Fig. 7.	Recommended PCB Guide – 3rd layer .....	10

---

## Contents

---

<b>1</b>	<b>Abstract</b> .....	<b>2</b>
<b>2</b>	<b>PCA9481A charging application</b> .....	<b>2</b>
2.1	50 W charging application at $IV_{BUS} \leq 3 \text{ A}$ .....	2
2.2	50 W charging application without additional 2:1 converter .....	3
<b>3</b>	<b>PCA9481A reference schematic</b> .....	<b>4</b>
3.1	Reference schematic with external FET controlled by PCA9481A .....	4
3.2	Reference schematic with OVP IC .....	5
3.3	I2C and other digital pins .....	5
3.4	NTC .....	6
3.5	AVDD .....	6
3.6	Input capacitor selection .....	6
3.7	Flying capacitor selection .....	6
3.8	Output capacitor selection .....	7
3.9	Bill of Materials (BOM) .....	7
<b>4</b>	<b>Layout guides</b> .....	<b>7</b>
	<b>Legal information</b> .....	<b>11</b>

---

Please be aware that important notices concerning this document and the product(s) described herein, have been included in section 'Legal information'.

---