



14-Channel Li-Ion Battery Cell Controller IC RE

BMI7014-MIM-PSP-TEST

Archived

本页面包含有关样品阶段产品的信息。此处的规格和信息如有更改，恕不另行通知。如需了解其他信息，请联系支持人员或您的销售代表。

Last Updated: Nov 20, 2024

The BMI7014 is a Li-Ion battery cell controller IC designed specifically for industrial applications including Energy Storage Systems and Uninterruptible Power Supplies. It features:

- Monitoring of up to 14 Battery Cells & 7 Temperatures.
- Configurable Averaging of Cell Voltage Measurements (Digital Filtering).
- Robust Isolated 2.0 Mbps Communication Interface.
- Onboard Balancing up to 300 mA.

14-Channel Li-Ion Battery Cell Controller IC Block Diagram

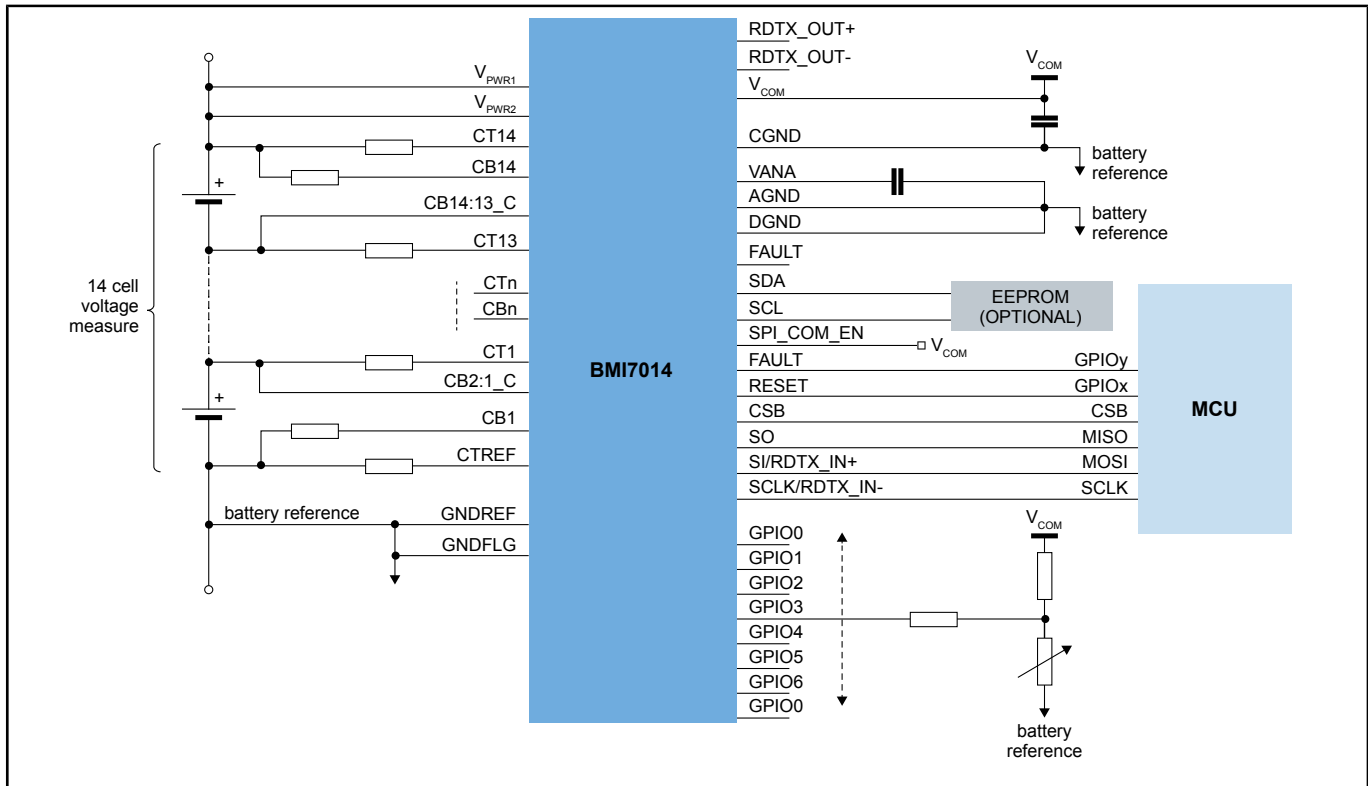

View additional information for [14-Channel Li-Ion Battery Cell Controller IC RE](#).

Note: The information on this document is subject to change without notice.

www.nxp.com

NXP and the NXP logo are trademarks of NXP B.V. All other product or service names are the property of their respective owners. The related technology may be protected by any or all of patents, copyrights, designs and trade secrets. All rights reserved. © 2025 NXP B.V.